

NEWS FOR THE ELECTRONICS INDUSTRY

element14

AN AVNET COMPANY

eTECH JOURNAL

ISSUE 6

DRIVING
THE FUTURE

+

POWERING UP

THE ADVANTAGES
AND CHALLENGES

EV CHARGING
STANDARDS

RENEWABLE
ENERGY

BATTERY
MANAGEMENT

THE ELECTRIC
REVOLUTION

FUELLING THE FUTURE

A JOURNEY TOWARDS
SUSTAINABLE MOBILITY



WÜRTH ELEKTRONIK MORE THAN YOU EXPECT

TAKING THE NOISE OUT OF **E-MOBILITY**



© e1505



Noise free e-mobility

e-Mobility is no longer a question of tomorrow and the number of e-vehicles is increasing day by day. Handling EMI noise is becoming more and more crucial, when it comes to design new electronic devices and systems. Würth Elektronik offers a wide range of EMC components, which support the best possible EMI suppression for all kinds of e-mobility applications. Besides ferrites for assembly into cables or harnesses, Würth Elektronik offers many PCB mounted ferrites and common mode chokes as well as EMI shielding products.

To learn more, [click here](#)

Highlights

- Large portfolio of EMC components
- More range with the latest semiconductor technology
- Fast charging with the innovative press-fit technology
- Longer life for less electrical waste with robust products

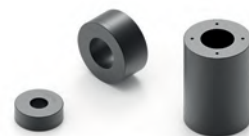

#EMCFOREMOBILITY



CONTENTS

WELCOME



In this era of profound transformation in the automotive landscape, EVs have emerged as the driving force behind sustainable transportation. We are thrilled to present the latest edition of e-TechJournal, "Fuelling the Future - A Journey Towards Sustainable Mobility", where we embark on an electrifying journey into the world of Electric Vehicles (EVs) and explore the cutting-edge technological developments shaping sustainable mobility.

Our featured articles provide in-depth insights into the latest advancements in EV charging technology. From the progress in automotive traction inverter systems, optimizing power conversion in EVs, to the importance of battery management for optimal performance and extended lifespan, we uncover the critical aspects of charging infrastructure. We also examine the integration of EV charging with renewable energy sources, maximizing sustainability in transportation through smart charging solutions and grid integration strategies.

Additionally, we explore emerging technologies revolutionizing the EV charging experience, such as wireless charging and ultra-fast charging stations, enabling fast, low-cost, and widespread charging infrastructure. Ensuring safety and interoperability is paramount, and we emphasize the significance of standardized charging protocols to ensure seamless compatibility and user safety across different networks. Finally, we focus on the design principles behind reliable and user-friendly EV chargers, addressing aspects such as power electronics, communication interfaces, and advanced safety features.

We hope this EV Charging Journal empowers you to be at the forefront of sustainable mobility, as we collectively strive to transform the future of transportation. Let us charge ahead together! Happy reading!

04 DRIVING THE FUTURE: TRACTION INVERTER SYSTEMS

12 POWERING UP WITH SAFETY AND EASE

18 THE ADVANTAGES AND CHALLENGES OF ELECTRIC VEHICLES

22 EV CHARGING STANDARDS: COMPATIBILITY AND SAFETY IN THE CHARGING PROCESS

28 EV CHARGING AND RENEWABLE ENERGY

34 EV CHARGING AND BATTERY MANAGEMENT - OPTIMAL PERFORMANCE AND LIFESPAN

40 BRING ON THE ELECTRIC REVOLUTION



To register for all future editions and to access all back issues of eTech Journal, scan QR code

Editor-in-chief: Cliff Ortmeyer, Managing Editor: Ankur Tomar

©Premier Farnell. All rights reserved. No portion of this publication, whether in whole or in part, can be reproduced without the express written consent of Premier Farnell. All other registered and/or unregistered trademarks displayed in this publication constitute the intellectual property of their respective holders. Errors and omissions in the printing of this magazine shall not be the responsibility of Premier Farnell. Premier Farnell reserves the right to make such corrections as may be necessary to the prices contained herein.



Cliff Ortmeyer Editor, eTech Journal
Email: editor-TJ@element14.com

DRIVING THE FUTURE:

MARKET AND TECHNOLOGICAL INNOVATIONS IN AUTOMOTIVE TRACTION INVERTER SYSTEMS



VISIT RENESAS

Author: Sam Gold, Director, Automotive Business Unit, Renesas Electronics Europe

INTRODUCTION:

The trend towards automotive electrification has accelerated worldwide in recent times, driven by the need for carbon neutrality and supported by stricter environmental regulations, core technology advancements, and declining costs. Most world regions are striving to tighten environmental regulations, with Europe leading the way, while greenhouse gas standards in other regions are following closely. Stricter GHG emission standards on the way, which may lead to temporary revitalization of the hybrid electric vehicle market as a early solution in the transition phase towards fully electric vehicles. However, mild hybrid systems are not enough to meet carbon emission regulations in several countries, and more advanced technologies are required to avoid fines for the OEMs.

As this GHG trend is accelerating, expectations are that the worldwide xEV market might be heading into a time of lengthy expansion, with battery costs also coming down. Tighter restrictions (fuel economy standards/BEV sales regulations) in countries across the board will create demand through around 2025, followed by a transition to a pattern of independent growth from 2025 onward as the core technology gradually becomes cheaper, including batteries.

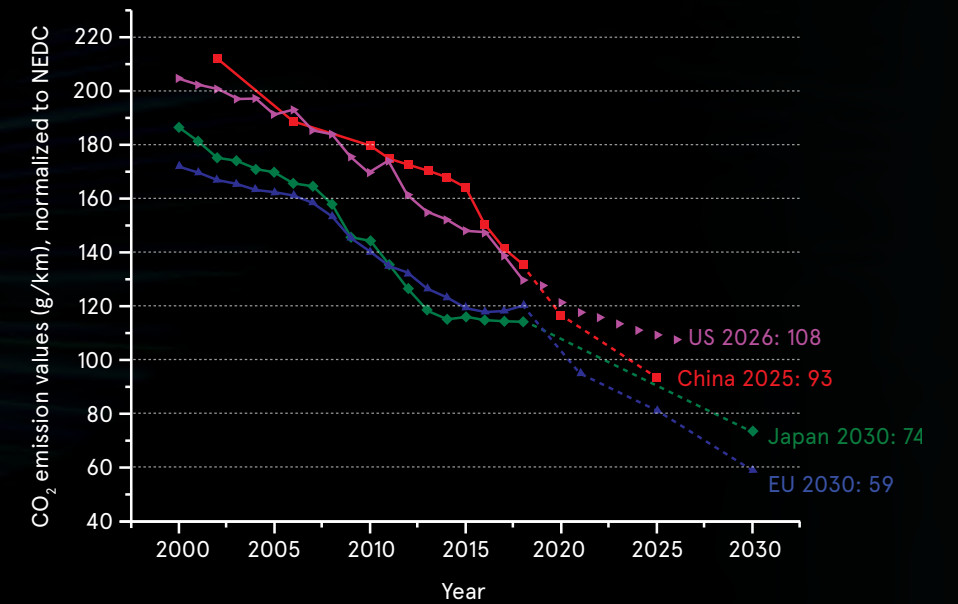

Figure 1: GHG regulation per country / region (Source: ICCT, 2020)

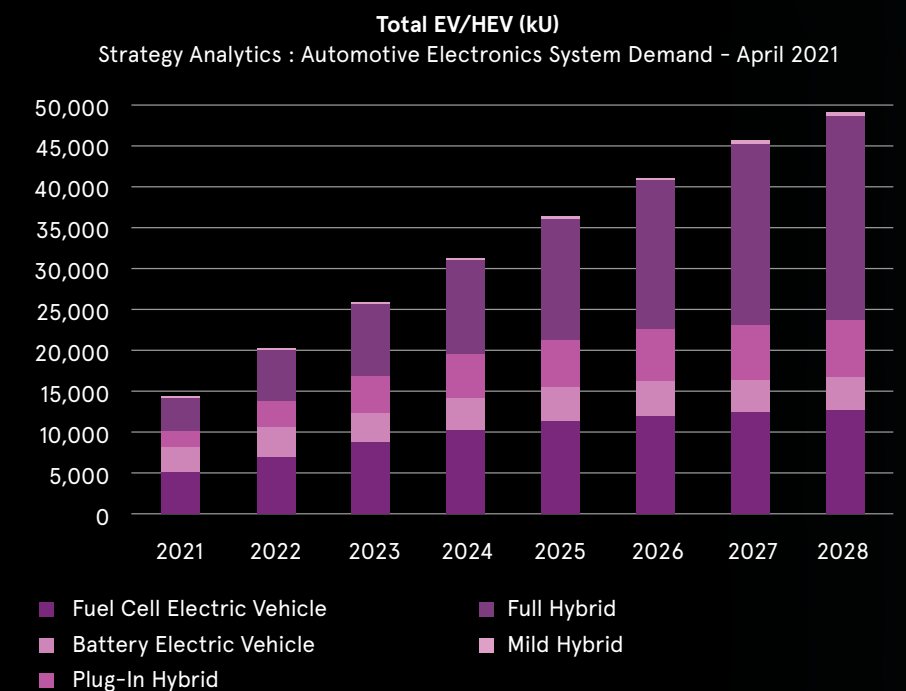

Figure 2: Source: Strategy Analytics - Automotive Electronics System Demand - April 2021 - Global xEV demand forecast of light-duty vehicles (excludes 2/3-wheelers, medium/heavy duty buses & trucks etc.)

HEV SYSTEM REQUIREMENTS AND CONCEPT

PHEV and FHEV especially, depending on the respective system concepts, have a higher complexity from a cooperative control strategy point of view (ICE and Electric drive), and on top of that are more sensitive to space restrictions of the application components simply because of the combination/addition of the ICE and e-drive functions. This is not only true for the electro-mechanical components, but for the electronics as well, such as the digital chipset, analog and power components.

The described system complexity results from the following top-level functionality: At vehicle deceleration, kinetic energy is converted into electric energy by the e-motor and stored in the battery. During acceleration, electric energy from the battery is used to assist the ICE, thus fuel consumption is saved. Having a high-powered e-motor for an FHEV means having high generator capacity so that more kinetic energy can be recovered (or recuperated) during deceleration, thus resulting in improvement of fuel efficiency in the range of several 10s of percent.

Before introducing a silicon IP concept that will help to solve the requirements complexity and space constraints mentioned above, let us briefly outline the challenges in HEV control. There are several kinds of hybrid architectures, where Figure 3 describes a top-level overview.

The simplest one is a Parallel hybrid system. A motor is placed in parallel with an ICE. The motor/generator assists acceleration by using electric energy from the battery and recharges the battery by using the motor as generator during deceleration. The benefit of this system is lower cost and less control complexity.

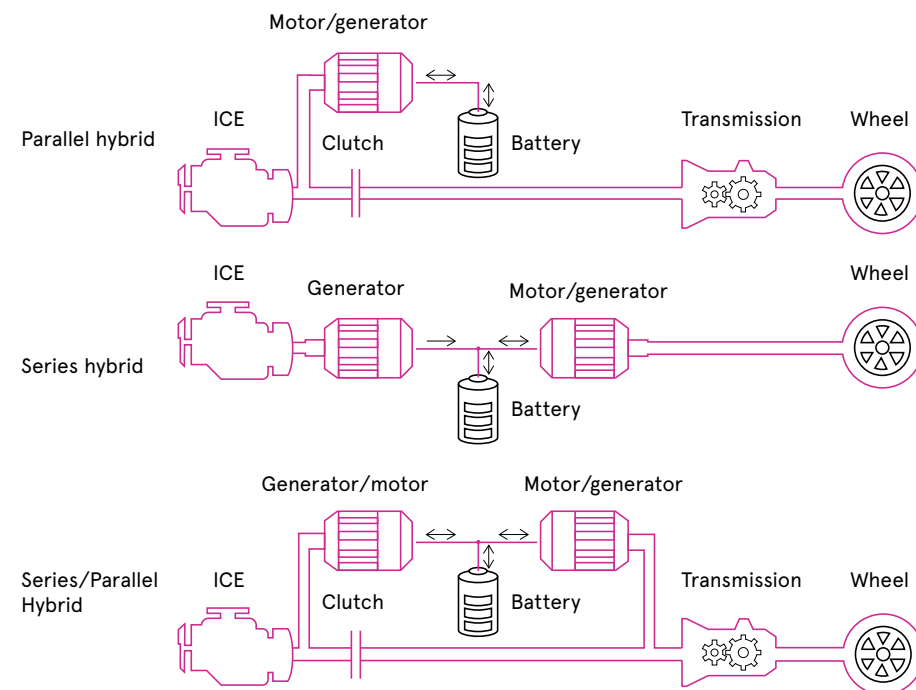

Figure 3: HEV top-level, Global Market Watch #504[Market and technology trends of xEV]

In the case of the Series Hybrid system, the kinetic energy created by the ICE is converted to electrical energy by a generator, and then the electrical energy is used to generate kinetic energy again by another motor. This may seem like it is wasting cost and energy. However, the advantage of this approach is that it allows operating the ICE in the most fuel-efficient speed/torque range. An ICE has poor fuel efficiency at low speeds (e.g., < 1500rpm), high speeds (e.g., > 4000rpm), and low torque regions.

The Series/Parallel hybrid is the most complicated system. When the ICE is operating in a fuel-efficient speed/torque range, the ICE output can be directly transferred to the wheels through a clutch and transmission. If torque assistance is needed, the e-motor can assist with acceleration and the ICE can save fuel like in a Parallel hybrid system. When vehicle speed is very slow, the clutch is disengaged, and the system behaves as a Series hybrid to avoid operating the ICE in a poor fuel-efficiency range.

In the case of Series and Series/Parallel hybrid system configurations, usually a combination of two motor/generator devices needs to be tightly and inter-dependently controlled.

HEV CONTROL: KEY CHALLENGE AND SOLUTION

From the previously introduced traction motor system concepts, it becomes obvious that the respective control and synchronization efforts especially in the case of the Series/Parallel hybrid system are complex, because of a high communication load between both entities as well as increased diagnostics efforts to maintain the targeted ASIL-level.

An obvious solution to optimize these efforts is to integrate both Inverter control systems into a one ECU, operated by a single and highly specialized Microcontroller (MCU). By using such a concept, the synchronization between both Inverter control loops can be implemented within one controller, resulting in high communication bandwidth and short latency. Furthermore, the diagnostics & Functional Safety concepts will become more straight forward by the selection of an ASIL compliant target device. Another benefit of an integrated solution is certainly a strongly optimized Bill-of-Material (BOM) which goes along with reduced component space requirements, both highly welcome effects for the overall system concept.

SOLUTION: MCU WITH INTEGRATED XEV SUPPORT FEATURES

A key asset for HEV application specific MCUs is to offload the calculation process of vector math for the motor control algorithm to a dedicated processing IP. By using this method, the MCU can be equipped with a smaller number of CPU cores while taking over other software tasks as described above.

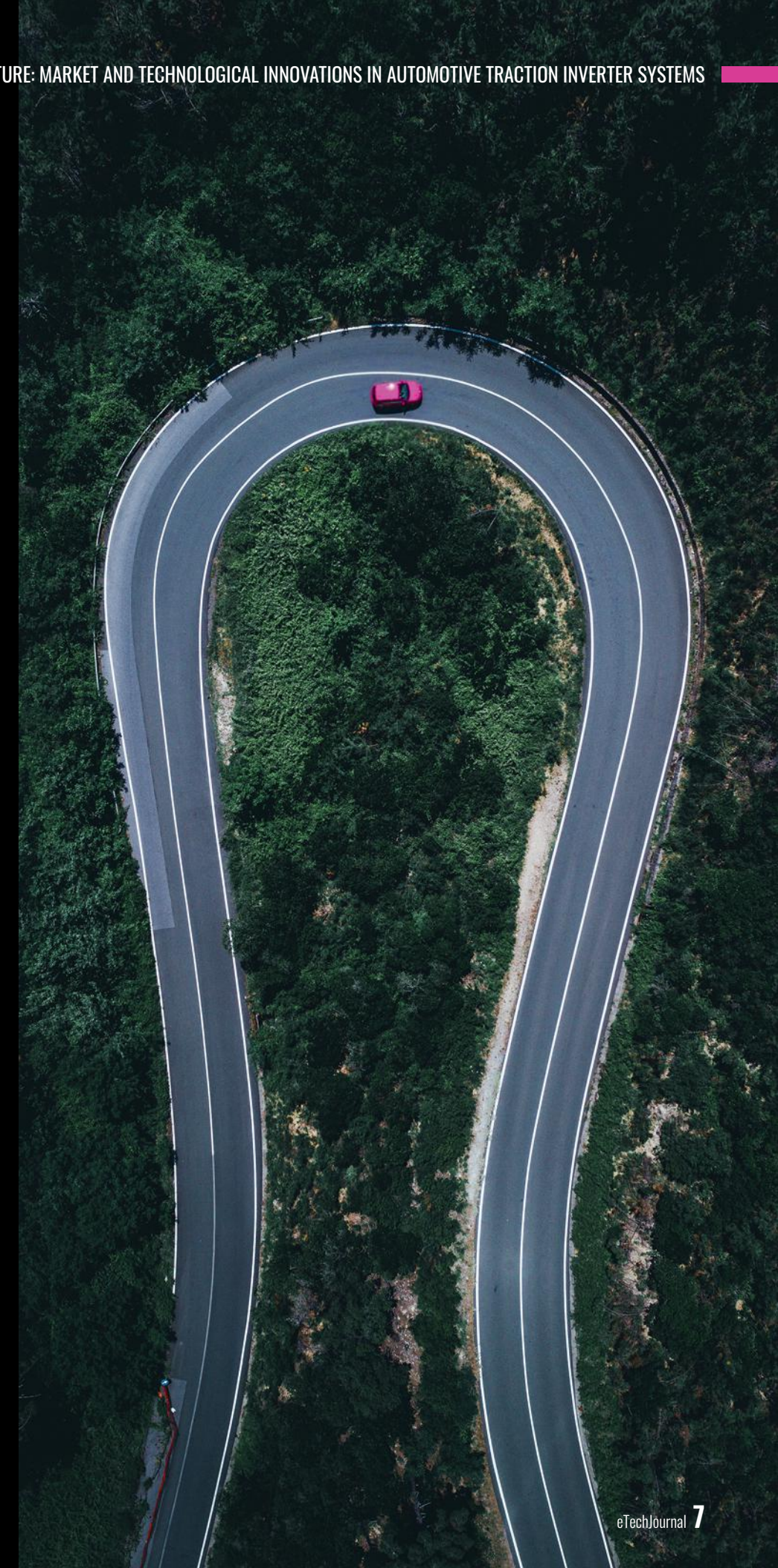

ENHANCED MOTOR CONTROL UNIT (EMU3)

The embedded "Enhanced Motor control Unit 3" (EMU Gen3) is a set of individual motor control accelerator modules that calculate the 3-phase PWM compare values using a vector control algorithm, generating rectangle wave patterns based on the motor current values measured by an A/D converter. Additionally, the motor's angle value is obtained through an integrated "Resolver to Digital Converter" (RDC3A), performing the position sensor interface function. The calculation results of the EMU3 are used by the TSG3, a 3-phase motor timer, to output PWM and rectangle waves.

Due to the HW-acceleration of vector math operations the EMU3 IP can calculate the next PWM setting value in a very fast manner.

Figure 4: Enhanced Motor control unit

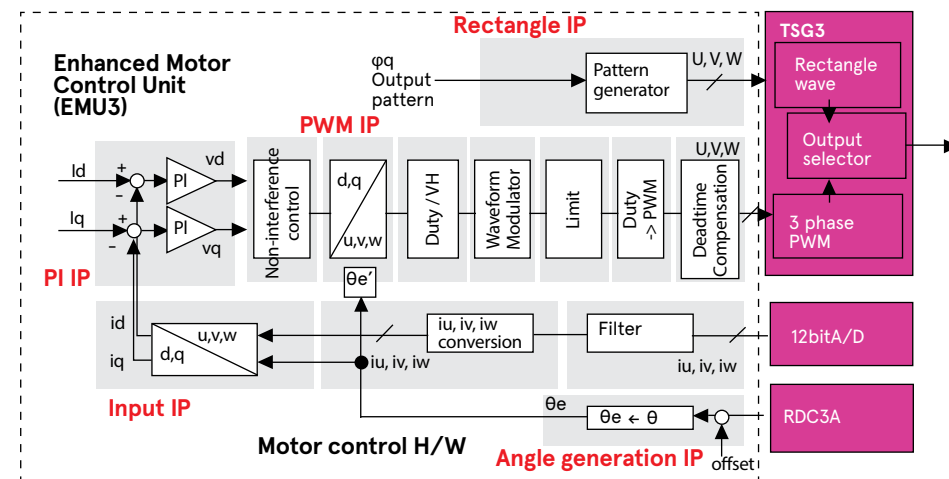

Figure 5: EMU3 performance

The EMU3 IP can exercise motor-control functions in combination with user specific software interventions between any of its functional blocks. Thus, a flexible control concept combining hardware acceleration and individual user software can be realized.

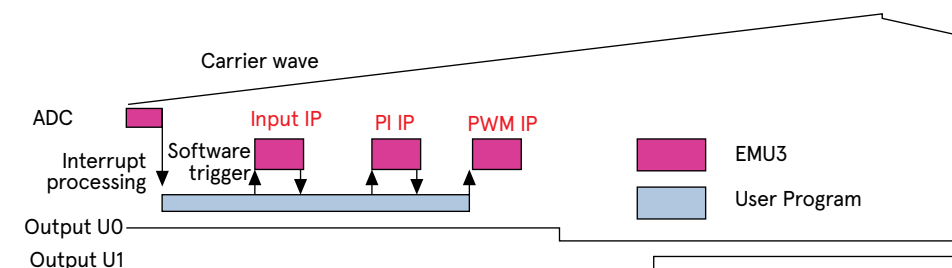
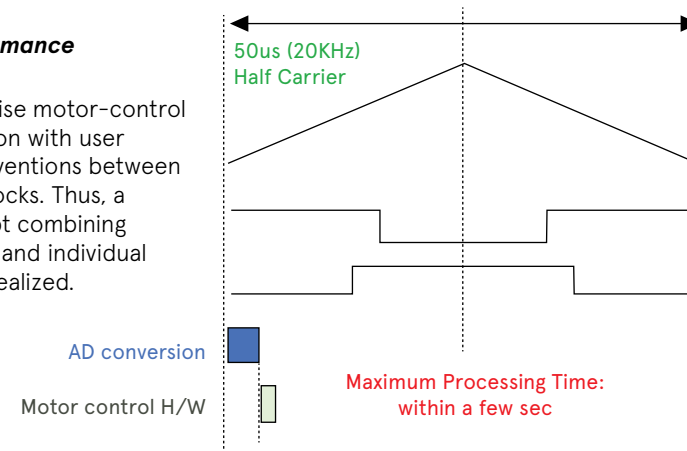

Figure 6: Flexible motor-control in combination with user specific software interventions

DUAL E-MOTOR/ GENERATOR CONTROL

The key solution to achieve dual e-motor/generator control capability is based on how the previously introduced motor-control IP ("EMU3"), as well as the embedded position sensor interface are incorporated into the Microcontroller system.

The following diagram shows the actual approach to control two e-motors (please refer to the Appendix for abbreviation definitions):

- CPU2 and CPU3 each controlling one motor respectively. By using the EMU3, the processing of performance-intensive motor-control algorithms, like the Park/Clark-transformation for PWM pattern generation, is shifted from the CPU to the EMU3. This allows the movement of other important software tasks, like diagnostic processing, to be performed by the CPUs.

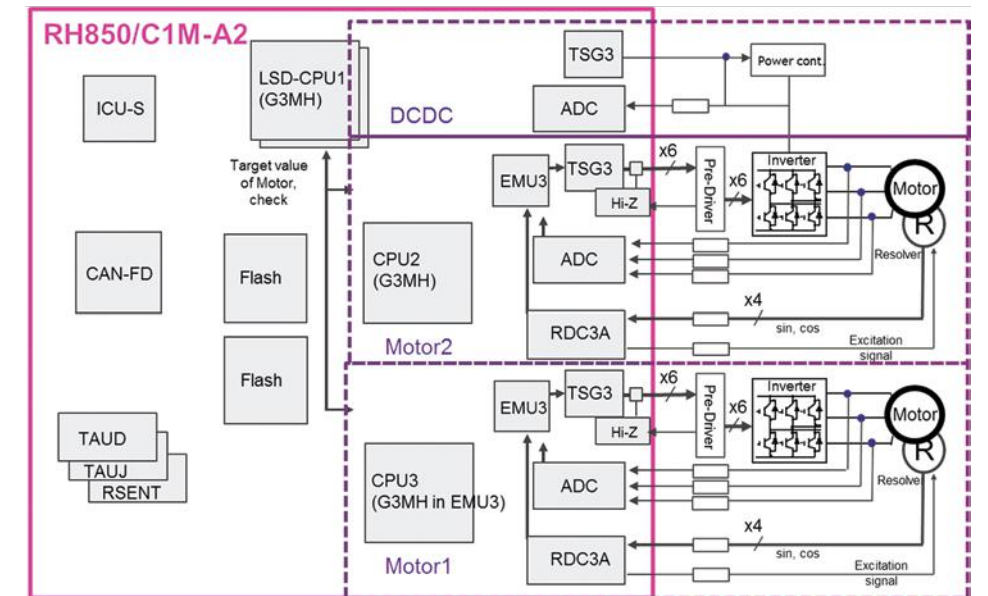

Figure 7: System example to control dual e-motor/generatorSummary

- CPU1 can be used for other functions: i.e., to realize DC/DC converter control as an optionally integrated add-on feature to optimize the overall HEV system layout. Other functions comprise communication control and "housekeeping functions", including diagnostics.
- RDC3A is the MCU integrated (Tamagawa AU6805-equivalent) dual Resolver-to-Digital Converter interface, or more generically, the motor position sensor interface, capable of connection to analog resolver- or inductive position sensor signals.

- Concerning position sensing, several OEMs are starting to follow a trend to replace conventional resolver concepts by much more cost-efficient inductive position sensor solutions. Here, the physical principle of Eddy currents supports to detect the position of a simple metallic target moving above a set of coils printed on a simple PCB. Renesas' inductive position sensing technology, the magnet-free IPS2550 delivers speeds up to 600krpm (electrical) and is designed around the motor, accommodating both off-axis (through shaft and side shaft) and on-axis positioning.

Hybrid vehicles that operate based on e-drive / ICE combinations are especially in need of cost-efficient and size-optimized propulsion systems due to the increased system complexity. Traction motor specific high-performance microcontrollers (MCUs) included with a dedicated HW accelerator function for vector math calculations can help to achieve an overall optimized electronic and electro-mechanic system design.

SOLUTION OFFERING BY RENESAS

At Renesas, generations of well-proven concepts for HEV-control exist within the 40nm Microcontroller, the RH850/C1M-Ax (R7F701275EABG). This device, and its soon to be released 28nm successors, focus on Inverter control functions for traction motors. As a comprehensive system solution inline with the MCU, Renesas is offering a suitable PMIC (RAA270000KFT), an inductive position sensor (IPS2550DE1R), gate driver (R2A25110KSP) and IGBT devices (IPS2550DE1R). On top, Renesas' reference SW (Application Note base) as inverter turnkey solution can significantly reduce customers' R&D efforts (see Fig. 8).

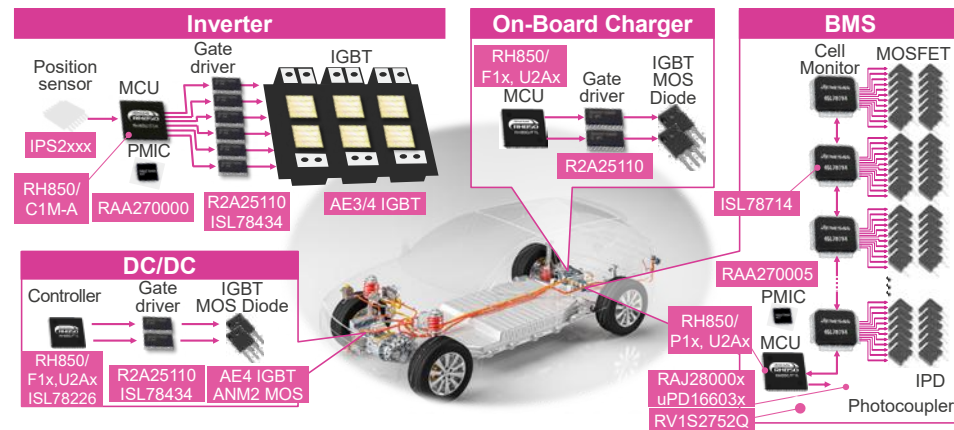

Figure 8 Renesas xEV portfolio

The ASIL-C compliant RH850/C1M-Ax is equipped with an RH850 32-bit G3MH lock-stepped CPU core, operating at a frequency of 240MHz for the C1M-A1. There are two G3MH cores, one of which is lock-stepped, operating at a frequency of 320MHz in the C1M-A2. Along with ROM, RAM and DMA, these devices include various timers such as a motor control timer (TSG3), various serial interfaces including CAN (CAN FD compatible), a 12-bit A/D converter (ADC), an R/D converter (RDC3A) that converts the resolver output signal to digital motor angle data, and a sub-CPU and parallel motor control unit (EMU3), providing peripheral functions that are ideal for motor control in HEVs & EVs. A comprehensive Eco-system with tools incl. model-based development is completing this comprehensive traction motor control solution.

Abbreviation	Description	Background
xEV	Comprising BEV, FHEV, PHEV, MHEV	Umbrella term
PHEV	Plug-In HEV	HV battery with >40KW e-motor
FHEV	Full (strong) HEV	HV battery with 20-40KW e-motor
MHEV	Mild HEV	48V battery with 5-13KW e-motor
ICE	Integrated Combustion Engine	Conventional combustion engine
MCU	Microcontroller Unit	
EMU	Enhanced Motor control Unit	
RDC	Resolver to Digital Converter	
TSG3	A 3-phase motor timer	
PWM	Pulse Width Modulation	
A/D or ADC	Analog to Digital Converter	
ICU-S	Integrated Cryptography Unit	
CAN (FD)	Controller Area Network - Flexible Data rate	
TAUx	Timer Units	
RSENT	SENT interface	
SEoC	System element out of context	

Figure 9 used abbreviations.

ABOUT THE AUTHOR:

Sam Gold is a Director in the Automotive Business Unit at Renesas Electronics Europe who has worked for the company for more than 15 years. He worked as an embedded automotive application specialist, field application engineer and technical marketer to gain broad knowledge of automotive microcontrollers and related applications for various segments. His current role in the company is related to product marketing and business development.

CONCLUSION

Explore more about Renesas RH850/C1M-Ax solution,

[CLICK HERE](#)

POWERING UP WITH SAFETY AND EASE: THE ART OF EV CHARGER DESIGN

As we seek more sustainable forms of transport, the advantages of electric vehicles (EVs) are becoming increasingly clear.



The success of electric vehicles depends largely on ensuring that EV drivers can charge their vehicles conveniently, either through home charges or at charging stations in towns, cities and at filling stations. EV charger design therefore requires consideration of where they are sited, how they are used, charging times and voltages, usability, safety, communications and security.

WHERE ARE ELECTRIC VEHICLES CHARGED?

Electric vehicles are charged at two types of site. The first is a destination charger, usually sited at facilities such as a carpark, shopping centre or other city centre site or at home. These use slow AC chargers.

The other is an en-route charger, often sited at filling stations along the highway. These employ high power, fast DC chargers that can provide accelerated charge times.

CHARGING STANDARDS AND SPEEDS

There are three main types of chargers:

- FAST CHARGERS
- RAPID CHARGERS
- HOME POINTS

FAST CHARGERS

Most of the public chargers being installed are 'fast chargers', essentially a wall mounted socket or a post with a pair of sockets. Charging can take several hours from 'fast chargers', but many EV drivers often simply require a 'top-up' charge and may plug in for an hour or so. Because of this, the occupancy of these chargers is unpredictable duration, requiring a certain amount of a flexibility of use.

RAPID CHARGERS

Because rapid chargers deliver charge at a higher current, they will therefore charge a vehicle faster than 'fast chargers', delivering around about 80% of the charge the car needs in the first 30 to 40 minutes. However, battery chemistry means they cannot fully charge a car at this same high rate - while it is possible to fully charge the car on a 'rapid charger' it will take over an hour. This is therefore an inefficient use of a 'rapid charger' and should be discouraged. They are also more expensive and require a higher capacity electrical connection. With a cable incorporated into the charger, they are similar in appearance to conventional petrol pumps.

HOME CHARGING

Home chargers are generally used off road on driveways and home garages. Charging generally takes place overnight using off-peak electricity. Some use captive cables, while others are essentially that make use of the vehicle's portable cable. Charging at work may be undertaken in a variety of ways although many businesses are installing home or fast chargers.

CONNECTOR TYPES

Car charging cables generally have two connectors, one that plugs into the vehicle socket and the other into the chargepoint itself. Electric vehicles will have either a Type 1 or Type 2 socket for slow/fast charging or a CHAdeMO or CCS for DC rapid charging.

Most slow/fast chargepoints have a Type 2 socket, while all DC rapid charging stations have a cable attached with mostly a CHAdeMO and a CCS connector. Most EV drivers will purchase a portable charging cable to match their vehicle's Type 1 or Type 2 socket to allow them to charge on public networks.

There are currently eight different connector standards in use, across AC and DC - varying from brand to brand and region to region.

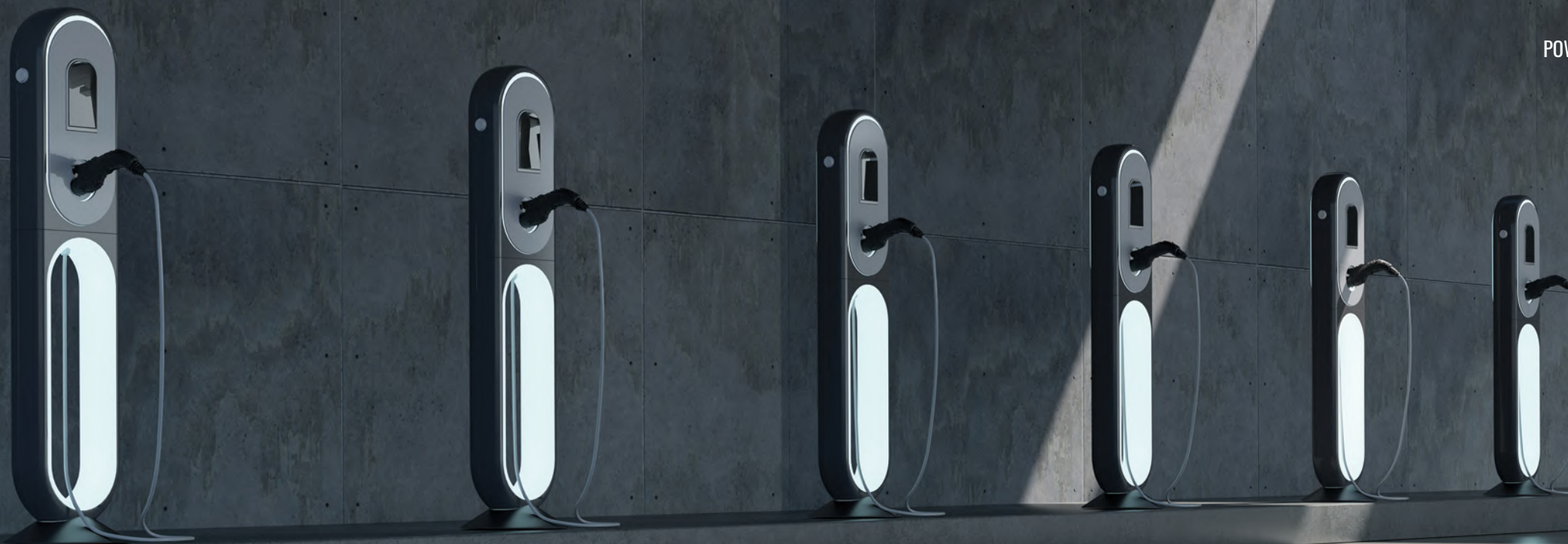

EV CHARGING STATION COMPONENTS

An EV charging station will typically comprise an electric vehicle charger, power grid, a facility meter, an energy controller, a software platform, the network operating center, power storage and several other relevant components.

These latter will consist of user interfaces, network connectivity and components to handle charge management and billing.

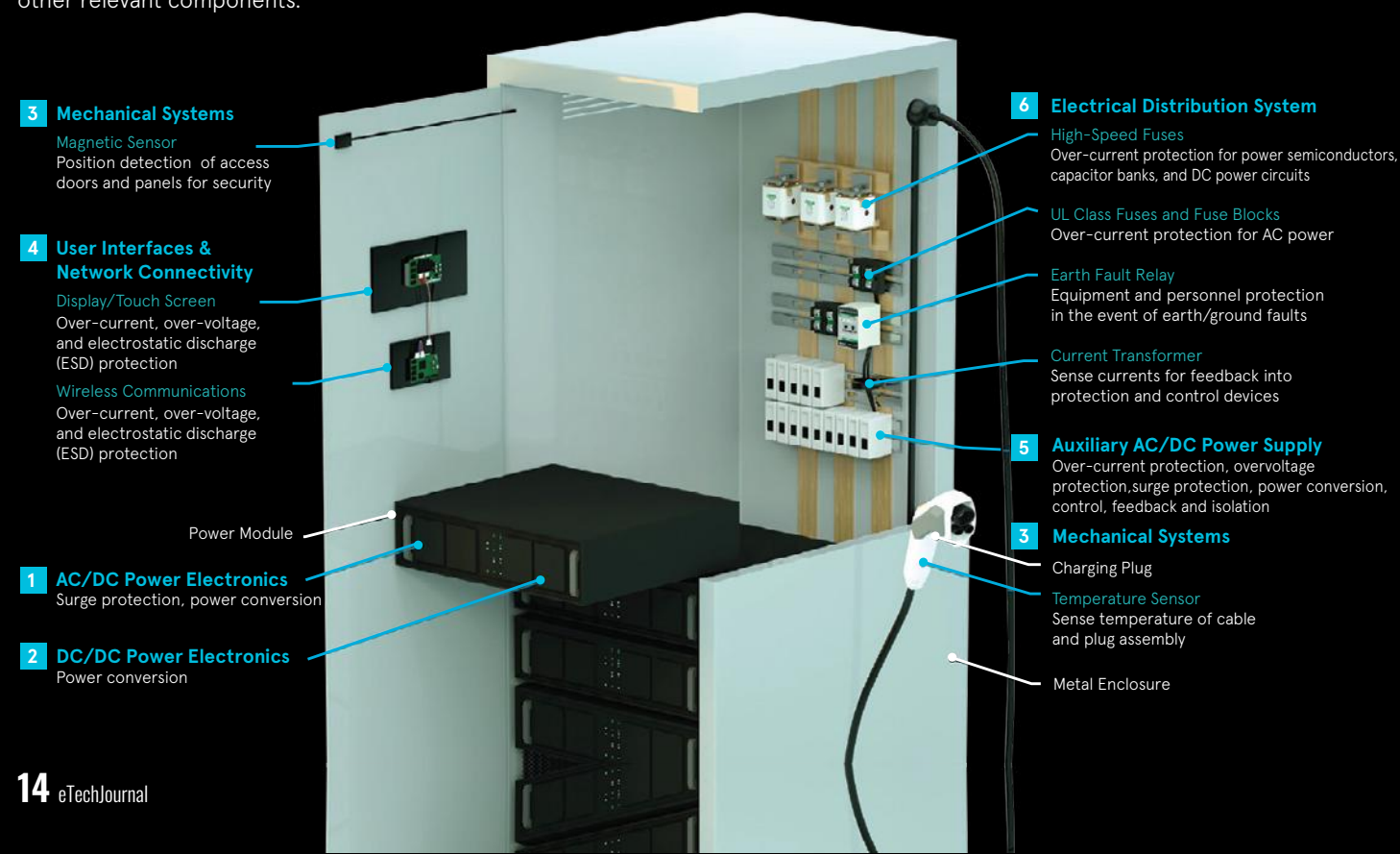

Figure 1: Components of a typical EV charger
– source TTI

ENERGY STORAGE FOR EV CHARGING

The power storage system at an EV charging station consists of three main units: battery, the power conversion system, and software.

The batteries are mainly lithium-ion batteries, consisting of cells and a battery management system (BMS) to control charging and discharging, while the power conversion system consists of an inverter and enclosure, and a HVAC system to maintain the battery at a specific temperature.

Electric vehicle charging software helps connect and monitor the charger, aids automatic fault detection, provides a live meter display, handles billing and payments, tracks costs and manages users, amongst other things.

SAFETY COMPONENTS

Safety is of paramount importance for users of EV chargers, particularly as many will not have experience of such high voltages. Today's typical EV chargers deliver 400V to 1,000V of DC power, potentially presenting safety threats from both electrical shock, usually as the result of a ground fault) and overcurrent.

A ground-fault protection device uses a current transformer on the phase conductors. This ensures that all current coming from the source returns on the same conductors. A ground fault in the system will return current through this path. Ground-fault protection is also required at the output side to avoid having drivers picking up a potentially live nozzle. This is achieved using a DC ground-fault monitor to detect an earth leakage and shut off power instantly.

EV charging stations need high voltages to meet the current demands and numbers of vehicles using them but allowing that power to exceed normal levels can produce many undesirable consequences – overheating systems, damaged insulation and even injury or death to users.

The solution is to select fuses based on their interrupting capacity, their rating based on normal operating current and their time-current curve. Such current limiting fuses operate quickly in the event of a high-value overcurrent.

Overcurrent protection is particularly important for semiconductors which are sensitive to electrical threats. These semiconductors are typically based on silicon and silicon carbide. Although conventional fuses are adequate to protect most of these, special high speed DC fuses are required to protect power semiconductor devices such as MOSFETS and IGBTs used in power converters.

POWER CONVERSION

Power conversion is a crucial element in DC fast charging systems. Minimizing losses in power conversion ensures that the maximum possible amount of power is to the vehicle's batteries – this also helps reduce heat build-up within systems.

Power semiconductor devices convert AC power into the DC power needed by the vehicle's batteries. The semiconductor devices control the charging through switching, which inevitably results in power losses as heat.

To meet this challenge, advanced power converters are increasingly based on silicon carbide (SiC) and gallium nitride (GaN) technology. The two major technologies in this area are SiC (Silicon Carbide) and GaN (Gallium Nitride).

SiC is a compound semiconductor composed of silicon and carbide. SiC power semiconductors can be used for much higher power device voltages than traditional silicon, ranging from 600V to thousands of volts. The technology is typically used in high power applications and offers lower switching losses and lower cost.

Gallium Nitride (GaN) is a very hard and mechanically stable semiconductor. A GaNFET will offer a much higher breakdown strength, faster switching speed, higher thermal conductivity and lower resistance than silicon based equivalents.

As well as handling much higher voltages than silicon, their high speed switching also makes them particularly suitable for battery management in electric vehicles.

ERGONOMIC ASPECTS

One of the major aspects of EV charger design is their usability – to ensure that EVs achieve the number of sales to sustain a viable market, users must be confident that chargers are easy to use and also that their data is secure.

This encompasses various aspects. One of the main considerations is cables and sockets. These need to have and ergonomically designed plug handle, with minimal resistance when a user needs to extend and manoeuvre the cable. Cables should also need to be a suitable length to reach the sockets on different vehicle models.

Other considerations include height and location of the chargepoint and cables to ensure safe operation by all users, sufficient illumination to allow night time use, payment options that are suitable for the chosen market, simple pricing structures and open access without the need for a subscription or registration process.

COMMUNICATIONS AND CONNECTIVITY

Easy, reliable and secure communications with the charge point are vital for both charge management and accurate billing.

Chargepoints generate a lot of data, which can include the chargepoint ID, the plug-in time and date, unplug time and date, and the total energy drawn in kilowatt hours.

Driver details such as payment method, account number and amount spent on the charging session will also be recorded. Data may also be required to accommodate 'smart charging', where the charger communicates with the car, the charging facility and the electric utility to optimize charging and avoid the need for expensive upgrades to the supply.

Various protocols are used for data exchange. The most basic communications protocol used in Type 1 and 2 AC charging systems between the charger and the vehicle is IEC 61851, which exchanges information such as when the charging starts, stops and the current the car draws.

OCPP is a global standard for charger communication with a back office. Created by the Open Charge Alliance (OCA), the specification has both required and optional features, ranging from basic charger control to high level security and reservations.

Because of this mass of data, achieving excellent, reliable connectivity – between the EV chargepoints, with the user and with the internet – is a must.

There are three main options here – hardwired, Wi-Fi or cellular.

Hardwired methods have the speed, capacity and reliability to handle the data exchanges needed, but the amount of cabling required to connect potentially widespread chargers could make the method impractical.

Wi-Fi is another option. Although avoiding extensive cabling, Wi-Fi has vulnerabilities to power outages, radio interference and malicious attacks.

Cellular gives each chargepoint access to mobile phone networks. Offering comprehensive coverage, high reliability and robust security, cellular is an ideal solution for connecting chargepoints.

CONCLUSION

The number of EV chargers is set to grow significantly, but they need to meet certain criteria if they are to have the confidence of both charge point operators and users. By taking account of the need for safety, efficiency, usability and connectivity, as well as accurate billing, EV charger designers can ensure the success of their products and contribute to the growth of the overall EV market.

[LEARN MORE](#)

THE ADVANTAGES AND CHALLENGES OF ELECTRIC VEHICLES

As the world seeks to curb pollution and move to more sustainable forms of transport, many people are pinning their hopes on the success of electric vehicles (EVs).

In terms of greener transport, they certainly offer a number of benefits over those powered by internal combustion engines (ICEs). The principal one is the avoidance of the use of hydrocarbon based fossil fuels, the source of much of the manmade world's production of greenhouse gases, as well as other serious pollutants such as carbon monoxide, nitrous oxide and airborne particulate matter.

In fact, in 2020, cars produced approximately 7.3 billion tonnes of CO₂, a figure that accounted for some 41% of the total for the transport sector as a whole – by contrast, the focus of many peoples' attention for emissions reduction, aviation, made up only eight percent of the total transport CO₂ emissions. [1]

With many cities and local authorities seeking to discourage the use of ICE vehicles through setting up low emission zones, EVs carry the additional benefit for users of attracting zero charges to enter these zones. Other attractions for EV drivers include their lower running costs. On average, an electric car costs less than £1.30 to drive for 100 miles compared to £11.05 for a petrol powered car. [2]

Another advantage for environmentally conscious drivers is the renewable energy tariffs available from some electricity suppliers. EVs can also provide a better driving experience, with more responsive acceleration and motors that can benefit from regenerative braking to capture energy when slowing down. EVs also tend to have a lower centre of gravity due to storing heavy battery packs low in the body of the vehicle, improving handling, comfort and safety. They are also quieter than ICE vehicles, reducing the burden of noise pollution in towns and cities.

Mechanically, EVs are also much simpler, particularly purely battery driven vehicles with a completely electric drive train. With far fewer moving parts, there is less to go wrong.

As authorities try to encourage further uptake of EVs, they also often benefit from government grants. Free or dedicated parking is also often available for EVs in several cities as municipalities try to dissuade drivers from taking ICE vehicles into urban centres.

Alongside the carrot of monetary incentives, there is also the stick of prohibitive legislation – sales of new ICE powered vehicles are becoming increasingly restricted or prohibited. Yet even here there is an advantage for users who make the switch early – with a complete ban in the UK from 2030, EVs will retain a better resale value as more drivers seek to access them in the absence of other options.

CHALLENGES TO EV ADOPTION

As well as the benefits driving forward the adoption of EVs, there are also some barriers to their wider use. Four of the major ones are charging infrastructure, EV performances, availability and affordability.

Charging issues have been a major barrier to the expanding the popularity of EVs, with particular pain points for drivers being lack of infrastructure, slow charging speeds, the cost of chargers and the lack of charging standards. Drivers of EVs still suffer from range anxiety, the worry that the vehicle will run out of battery charge before they can reach another charging point.

This anxiety could be the reason why there is much greater interest in hybrid technology in most markets, significantly outstripping the interest in full Battery Electric Vehicles (BEVs) by some margin.

According to the Global Automotive Consumer study 2023 by Deloitte [3], most potential EV buyers expect to be able to charge their EVs at home and only 16% of potential EV purchasers in the United States anticipate using public chargers as their regular charging option. EV manufacturers are also asking for DC/DC charging compatibility to allow a 400V DC charger to charge an 800V battery to mitigate the gaps in the 800V charging network availability. This will aid market growth by offering a greater variety of charging options for drivers.

The time to charge an EV has also been cited as a drawback and much attention has been given to fast chargers that significantly reduce the wait, putting it on a par with refuelling an ICE vehicle. However, findings in the Deloitte report suggest this factor has been overstated, with drivers prepared to wait substantially longer than 10 minutes to recharge their batteries.

Performance is another challenge. The speed and torque output of a motor are inversely proportional and are limited by the total power output of the motor. This presents a challenge that is difficult to solve cost effectively.

Providing highly efficient power from the batteries to the vehicle's loads is also increasingly important as comfort loads such as active suspension, heated seats and rear steering wheels are placing further demands on power.

Vehicle manufacturers are realizing that 12V architecture has been developed as far as it can be. They are now more willing to use innovative approaches to deliver better performance. EVs today still maintain a 12V battery to power non-traction related functions such as windscreen wipers, seat comfort controls, and infotainment.

Some manufacturers are replacing the 12V battery with a 48V unit for their latest models – the thinking is that, rather than rely on a separate 12V battery, why not create a virtual battery from the vehicle's primary 400V or 800V battery pack? This allows manufacturers to save considerable weight in their vehicles, while also rationalising costs related to engineering, supply chains and the stocking of spare parts.

Other performance issues include battery capacity and the range they can provide. For example, battery capacities of current EVs range from a mere 17.6 kWh in the Smart EQ ForTwo with a range of just 58 miles, up to 100 kWh in the Tesla Model S that offers a maximum range of 351 miles.

Battery design, for example, is undergoing major innovation into new chemistries and methods of construction. Although these developments are still in their infancy, there are promising results already.

Battery swapping, a common concept in China, aims to avoid range anxiety by allowing electric cars to extend their range by exchanging a discharged battery for a charged one at a swapping station.

EVs employ over 50kW of electrical power, compared to less than 3kW in an ICE vehicle. The nearly 20 times increase in power requires compact power solutions to free up space and weight. Reducing the size and weight of the power delivery network are essential factors. For example, the Vicor BCM6135 delivers 2.5kW of power from a unit that weighs only 65 grams and which can be held in the palm of your hand.

The limited availability of electric vehicles is also among the major barriers to EV adoption. Today, there are only 29 fully electric consumer vehicle models available in North America. By contrast, there are more than 400 different models available in fuel-based alternatives.

The affordability issue is largely governed by the cost of the powertrain – 51% of total cost on average as compared to 18% of total cost for internal combustion engine powertrains. Efforts to reduce the size and weight of the power delivery network will be essential factors in the ultimate success of EVs.



PROVING PERFORMANCE

The confidence of EV users is a major factor in the continuing take up of EVs – they need to know that electric vehicles have the range, performance, reliability and handling characteristics they demand.

This demands a rigorous testing regime with development engineers requiring specialised equipment for each testing use case.

The four major subsystems that manufacturers need to test are:

- Charging – of the battery, charging monitoring systems and regenerative braking
- Powertrain – the power inverter sub-system for power delivery, and its associated control signals
- Motors – three-phase brushless DC motors used in various applications such as windows and air conditioning
- Steering systems – Steering characteristics and electronic power steering

As well as research and development testing, there is a need to test electric vehicles during their production. This demands a new generation of more portable test equipment that allows in-car testing of different parameters in the field and which can operate in different climatic and road conditions.

Autonomous vehicles are also making increasing use of sensors that will also need maintenance, with specialist sensors such as LIDAR requiring equipment like optical spectrum analyzers to assess their performance and accuracy.



CONCLUSION

Despite the major advantages offered by EVs, challenges persist in such critical areas as vehicle charging time, driving range, and access to efficient EV charging stations. However, the mass electrification of transport is well under way. Engineers can meet the challenges with the technologies they have in place, but ultimately mass adoption and deployment will only be effective and profitable if governments and regulations support it and if EV vendors can ensure that users have the confidence in the vehicles that they need.

REFERENCE - 1

REFERENCE - 2

REFERENCE - 3

EV CHARGING STANDARDS: ENSURING COMPATIBILITY AND SAFETY IN THE CHARGING PROCESS

EV charging standards are instructions and guidelines that ensure the safe and compatible charging of electric vehicles (EVs).

These standards include electrical specifications, grounding requirements, and other safety features crucial for promoting EV adoption and growth. The standards for EV chargers, also known as electric vehicle supply equipment (EVSE), vary by country and depend on the available EV models and electrical grid characteristics. Charging standards govern the connection between the EV and the EVSE, including physical connectors, communication protocols, and electrical parameters for charging electric vehicles. By adhering to these standards, various types of vehicles can ensure compatibility with multiple types of electric vehicles.

CHARGING STANDARDS

Charging standards are developed by international organisations such as the International Electrotechnical Commission (IEC) and the Society of Automotive Engineers (SAE). These organisations bring together technical experts, manufacturers, and government agencies to create standards that are widely adopted by the industry. Some countries also have national standards organisations that may differ slightly from the international standards. To ensure compatibility and ease of use for EV owners, most EVs and charging stations are designed to be compatible with international and national standards.

a) Society of Automotive Engineers (SAE)

SAE has developed two standards related explicitly to charging electric vehicles: SAE J1772 and SAE J3068. The SAE J1772 governs AC charging for Levels 1 and 2, including the charging connector (the "J1772 plug") and communication between the EV and the charging station. The standard supports a range of single-phase AC charging rates, from portable devices that can connect to a standard 120-volt outlet to home and public charging stations with higher power levels. It includes plug type; current type; current phase; wattage; voltage; plug size; plug shape; cord length; and plug color.

The SAE J3068, in contrast, covers DC fast charging, including specifications for the charging connector and communication protocols.

b) International Electrotechnical Commission (IEC)

IEC 61851-1, IEC 61851-23, and IEC 62196 are key standards that provide technical specifications for charging connectors, communication protocols, and other components of EV charging systems.

- IEC 61851-1 is a standard for AC charging that covers the physical connection between the EV and the charging station and communication protocols between the two.
- IEC 61851-23 is a standard for DC fast charging that also covers the physical connection between the EV and the charging station and communication protocols.
- IEC 62196 is standard for AC and DC charging, covering the charging connector and communication protocols.

EV CHARGING LEVELS

Electricity distribution systems supply AC power, which must be converted to DC power for charging the battery pack in EVs. This is done using a converter. Figure 1. depicts the charging process of electric vehicles through AC or DC infrastructure. DC charging provides considerably faster charging speeds than AC charging. An AC EVSE employs the onboard charger of the EV to convert the AC power delivered by the charging station into DC power. Conversely, a DC EVSE directly supplies DC power to the battery by converting the power externally, bypassing the onboard charger.

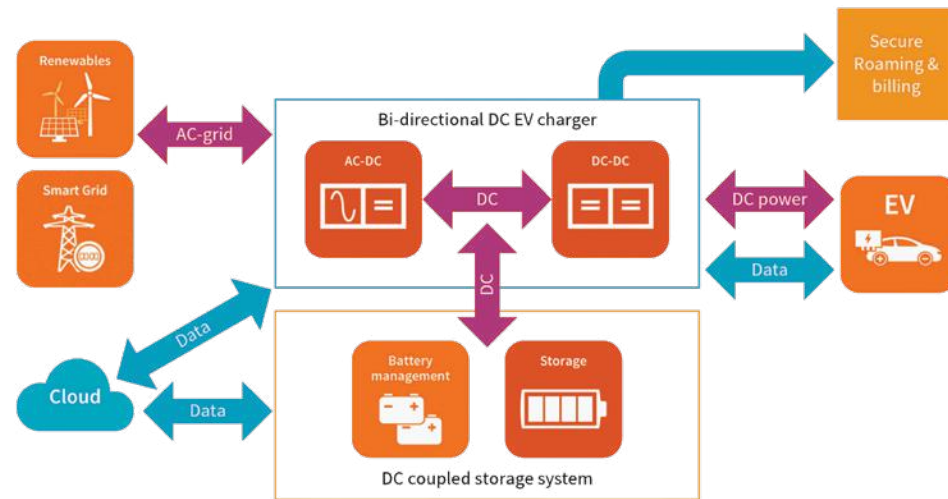

Figure-1: The basic structure of a bi-directional EV charging

There are three levels of EV charging:

- > Level 1 (L1) charging is the most basic and affordable option. This is typically done through standard 120V outlets and can take up to 8 hours to charge a vehicle. L1 charging is ideal for those with minimal EV needs or who need access to higher-level chargers. It delivers low power loads (1-2 kW) and has relatively longer EV charge times (approximately 4 miles/6.4 km of light-duty vehicle range per hour of charging).
- > Level 2 (L2) charging uses AC to deliver power through a specialised higher-voltage connection. This is the most common type of charging used at home and in public, delivering between 6.6 kW and 19 kW of power. It requires a 240V outlet and takes 4-6 hours to recharge a vehicle fully. L2 charging is the most convenient vehicle charge and is widely available in public locations.
- > Level 3 (L3) charging, also known as DC Fast Charging, is the fastest way to charge an EV. This type of charging is only supported by specific vehicle models and requires specialised equipment. It provides high power levels (50-400 kW) using specialised charging equipment and can give an 80 per cent charge in as little as 30 minutes. Table-1 summarises the different levels of charging.

Charger type	Supply voltage	Phase	Type of use	Energy supply interface	Power level	Charging time
Level 1	120 V	1 phase	Charging at home or office	Conventional outlet	1.4-1.9 kW	17 Hours
Level 2	240 V	1 or 3 phase	Charging at private or public outlets	Dedicated chargers	3.1-19.2 kW	8 Hours
Level 3	300 - 600 V	3 phase	Charging at station	Dedicated chargers	50-240 kW	30 minutes

Table 1: EV charger type classifications



MODES OF EV CHARGING

There are four different charging modes. These are called modes 1, 2, 3, and 4, specified by the IEC 61851 standard. Figure 2 illustrates the different modes of connecting EV chargers.

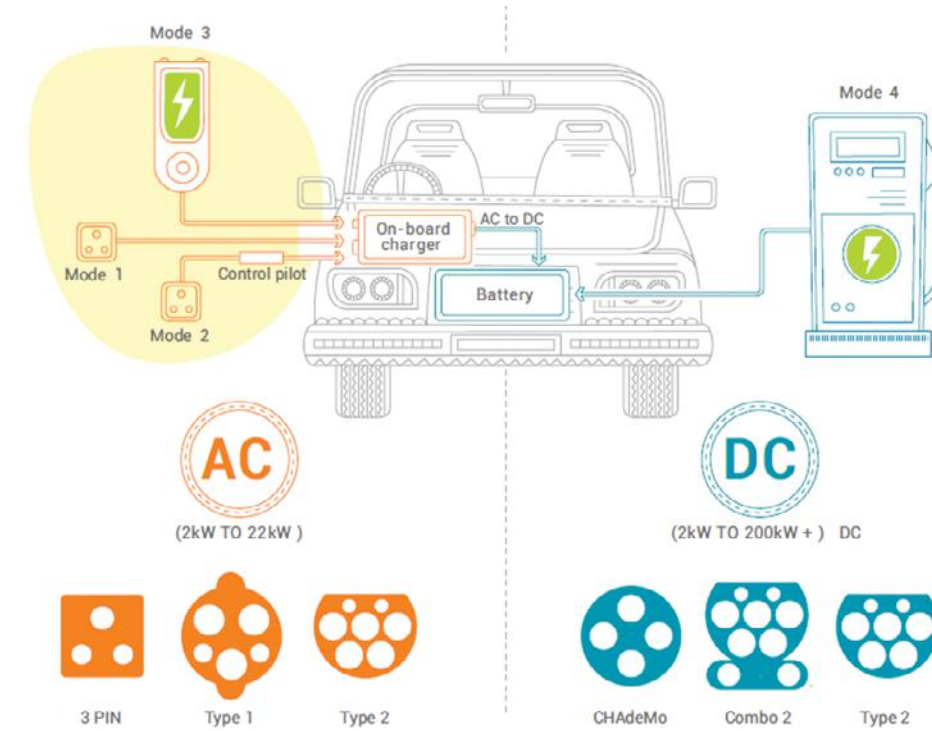

Figure 2: Different EV charging methods

- > In Mode 1 charging, an EV uses a cable and plug to connect to a standard household socket outlet. There needs to be more communication between the EV and the EVSE, so it is occasionally used.
- > Mode 2 uses a particular type of charging cable equipped with an in-cable control and protection device (IC-CPD). The inbuilt protection and control capability prevents overcharging and ensures safety and efficiency. This makes it suitable for home charging. The maximum current of this mode is 32 A. Mode 2 can be used with both household and industrial sockets (250 V single-phase or 480 V three-phase)
- > Mode 3 charging utilises an EVSE that communicates with the vehicle to negotiate the charging parameters, such as charging speed and time and can also provide feedback on the charging process. It utilises a dedicated EVSE along with the EV onboard charger. The maximum current of this charging mode is 250 A with either a 250 V 1-phase or 480 V 3-phase network.
- > Mode 4 charging, also known as DC fast charging, bypassing the onboard charger, uses a high-power charger that directly provides DC power to the vehicle's battery. It can provide 600 V DC with a maximum current of 400 A and demands a higher level of communication and stricter safety features. It can charge an EV up to 80% in as little as 30 minutes.



RAPID CHARGING STANDARDS

Rapid charging is a type of charging for electric vehicles (EVs) that can provide faster charging than normal charging. Rapid charging typically uses a high-powered charging station, which can provide a large amount of electrical power to the EV's battery in a short amount of time. There are several different rapid charging standards used around the world, including CHAdeMO, Combo Charging System (CCS), Tesla Supercharger, and GB/T. Each of these standards uses a different connector and communication protocol, which means that they are largely incompatible with one another.

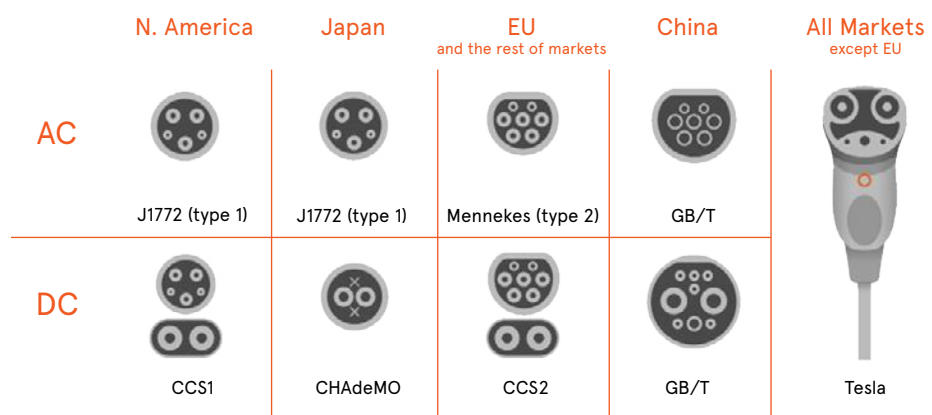

Figure 3: Depiction of different AC and DC EV connectors

EV CHARGING STANDARD CONNECTORS

EV standards provide guidelines for manufacturers to create an EVSE that can be connected to a vehicle's charging inlet. These guidelines cover the shape and size of the connector, as well as basic safety requirements and charging limitations.

Figure 3 displays the EV connectors used worldwide for AC and DC charging. AC charging uses power directly from the electric grid, whilst DC charging requires two additional dedicated DC pins. Additionally, all chargers require extra pins for communication or controls.

Charging station Level	Connector Interface type
Level 1 AC charging 1-2 kW	Standard wall outlet
Level 2 AC charging 2-20 kW	SAE J1772 Type 1, IEC62196 Type 2, GB/T
DC Low power charging 20-50 kW	SAE J1772 Type 1, IEC62196 Type 2
Tesla supercharger DC Charging 50-250 kW	Tesla
DC High power charging 50-500 kW	CCS1, CCS2, CHAdeMO, GB/T DC

Table 2: EV charging connector used by different levels of charging station

WIRELESS EV CHARGING STANDARD

This is a newer technology that allows EVs to charge without the need for cables or plugs. Wireless charging technology is becoming increasingly popular as it allows EV owners to charge their vehicles without having to plug in a physical cable.

SAE J2954 is a wireless charging standard developed by the Society of Automotive Engineers (SAE) that outlines the technical requirements for wireless power transfer (WPT) systems used for EVs and autonomous vehicles. The SAE J2954 standard defines the technical requirements for both the charging pad and the receiving pad, including the power output, frequency, and communication protocol. WPT systems work by parking in a wireless charging spot, with the vehicle positioned over an SAE J2954-compatible ground assembly pad. After a communications handshake, charging begins automatically without a physical corded connection.

CONCLUSION

Please visit our Technical Resources hub to explore the most recent trends, technologies, and design resources for Electric Vehicles (EVs).

[CLICK HERE](#)



EV CHARGING AND RENEWABLE ENERGY: MAXIMISING SUSTAINABILITY IN TRANSPORTATION

The adoption of Electric Vehicles (EVs) improves air quality and helps reduce greenhouse gas emissions.



Such adoption, however, needs a reliable and convenient charging infrastructure, including smart EV charging. Renewable energy sources (RESs), such as solar photovoltaics (PV) and wind energy systems, can fill these infrastructural gaps and help to decarbonise the environment. RESs can also help reduce PV ownership costs by providing low-cost electricity.

Wind power and PV are variable energy sources, making it challenging to power electric cars with renewable energy. To overcome this difficulty, wind and solar installations must be sized to ensure sufficient energy, even during minimal sunshine and wind periods. This approach guarantees adequate energy generation and storage for charging electric cars, even when renewable energy generation is low. Such an approach also significantly reduces their carbon footprint.

Renewable-based charging stations can be of two types: grid-connected and standalone. An additional storage system is essential for providing a continuous power supply in a standalone system. The transmission system is vital in always ensuring the balance between consumption and production.

CHARGING FROM WIND ENERGY

Wind energy is a renewable energy source that can charge EVs without depleting natural resources. The wind farms are located distant from electric vehicle charging facilities, and the electricity generated by wind turbines is transmitted long distances to charging stations through the power grid. Wind turbines do not produce greenhouse gas emissions or air pollutants.

A wind turbine is typically rated in the order of megawatts, whilst an EV charger usually works in kilowatts. A single wind turbine can charge several hundred cars.

Some of the challenges associated with using wind energy EV charging are:

- ▶ Wind turbines generate electricity only when there is sufficient wind, which can vary throughout the day and from season to season. Wind generation is maximum in winter and in the night time. Hence, wind generation is ideally suited for charging electric cars at home at night.
- ▶ Excess wind energy produced during periods of high wind needs to be stored in energy storage devices and delivered during periods with less wind. The intermittency of wind energy requires energy storage systems to ensure reliable and continuous EV charging services.

Renewable energy sources such as solar and wind can be unreliable due to their irregular output. To ensure a consistent power supply, combining multiple energy sources is recommended. Solar panels and wind turbines are easy to integrate and ideal. Figure 1 shows a horizontal axis wind turbine with a permanent magnet synchronous generator (PMSG) and uncontrolled diode bridge rectifier. The Wind Energy Conversion System (WECS) needs to operate at variable speeds to be effective.

The wind energy field commonly uses MPPT methods to maximise power output in wind turbines. These methods adjust the generator speed to track the maximum power point of the turbine.

The most popular methods include Tip-speed ratio (TSR), Perturb and Observe (P&O), power signal feedback, and Fuzzy Logic Control.

The TSR algorithm adjusts the generator speed to achieve the optimal tip-speed ratio, maximising the wind turbine's power output. The P&O algorithm is effective for all turbine types because of its simplicity and efficiency. It adjusts the generator speed based on the difference between measured power output and a reference value without requiring knowledge of turbine characteristics or operating conditions.

The optimal MPPT method may vary based on the turbine design and operating conditions. Therefore, a thorough analysis is recommended before selecting a control strategy.

Figure 1: Integrating Solar and Wind energy for EV battery charging

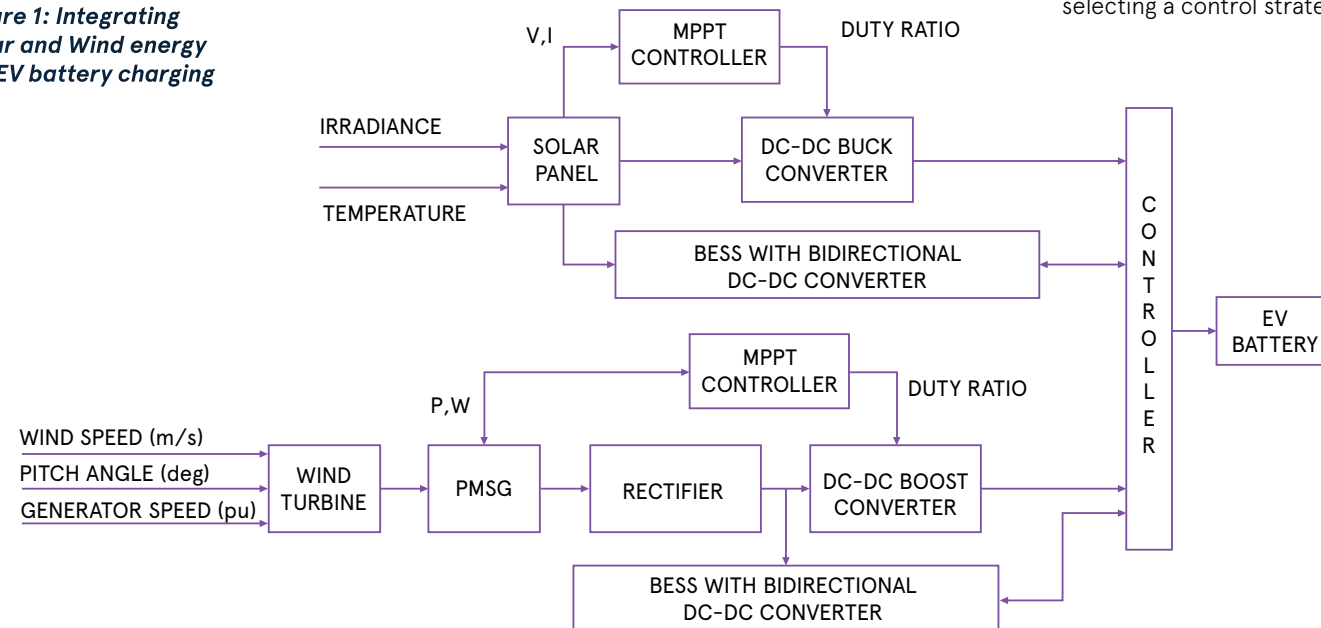

CHARGING FROM SOLAR ENERGY

Electric vehicles may be charged using solar energy, which is cost-effective and environmentally friendly. Solar panels can be installed on rooftops or on the ground to generate electricity from the sun, and the energy can be stored in batteries or directly used to charge electric vehicles. By combining electric vehicles with solar energy, we can create a sustainable and efficient transportation system that benefits both the environment and our economy.

One of the advantages of solar panels is their ease of installation on rooftops, making it possible to generate solar power close to where electric vehicles will be charged.

This reduces transmission losses and improves efficiency. Rooftop solar PV systems are typically rated in kilowatts, similar to the power rating of an EV charger. Unlike wind generation, solar generation is highest during the day and in the summer. This makes solar generation ideal for charging electric cars at workplaces during the day when energy demand is high. By utilising solar power for EV charging, we can reduce our reliance on fossil fuels, lower carbon emissions, and decrease our impact on the environment.

The power and current curves of a solar panel with respect to voltage are nonlinear. The nonlinear nature of solar panels shows the requirement for using the MPPT algorithm.

The maximum power occurs at different voltage values for changing irradiance. Several popular algorithms, such as P&O, Incremental Conductance (IC), and MPPT using fuzzy logic, are used in solar photovoltaic systems. The IC method is particularly effective in swiftly varying solar radiation conditions. This method uses a search strategy to adjust the converter duty ratio, causing the solar panel voltage to change and search for the maximum power point. The search ends once the desired point is reached. The IC method effectively maximises power output and ensures the efficient operation of solar photovoltaic systems, especially in rapidly changing environmental conditions.

To create a solar-powered EV charging station, a solar inverter is the simplest method. A DC-to-DC power converter operates the solar panels at the maximum power point, and a DC-AC inverter converts the DC power to 50Hz or 60Hz AC power for AC charging of the EV. However, this method could be more efficient as it converts DC power to AC and back again. A more efficient approach is using an isolated DC-to-DC converter to charge the EV from PV using DC charging directly. As shown in figure-2 10kW solar-powered charger, this method includes a DC-to-DC converter for the solar panels, an isolated DC-DC converter for the EV, and a DC-to-AC inverter to connect to the AC grid. This method also allows the EV battery to be used as storage for renewable energy.

Figure 2: Solar panel EV charging block diagram

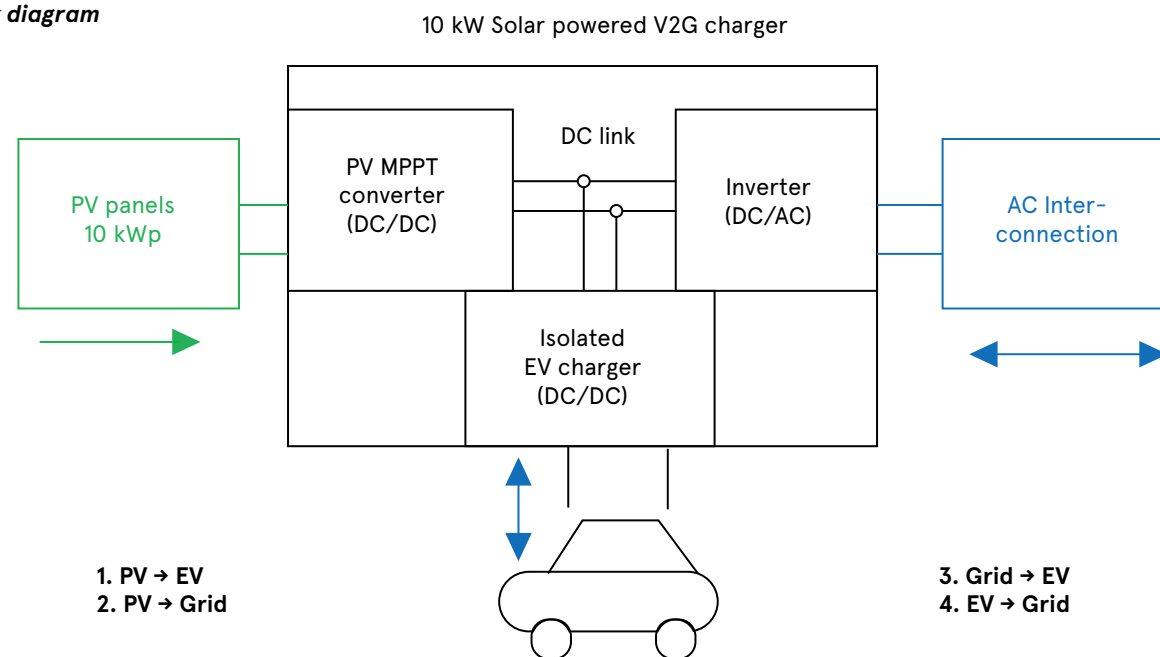

CONCLUSION

Please visit our Technical Resources hub to explore the most recent trends, technologies, and design resources for Electric Vehicles (EVs).

[CLICK HERE](#)



EV CHARGING AND BATTERY MANAGEMENT: ENSURING OPTIMAL PERFORMANCE AND LIFESPAN

Electric and hybrid electric vehicles rely on high-voltage battery packs to power their electric motors. These packs are crucial as they store the energy required to run the vehicle. To ensure the optimal functioning of these battery packs, a battery management system (BMS) is used. The BMS has multiple roles, including prolonging the battery's lifespan and increasing the vehicle's driving range. BMS achieves this by regulating the charging and discharging of the battery packs.

LI-ON BATTERY CHARGE PROFILE

Lithium-ion batteries are the most commonly used technology in electric vehicles due to their high energy density (100-265wh/kg) compared to other battery types. Li-ion batteries are designed to be charged up to a specific voltage and then stopped to prevent instability and potential fires. It's essential to ensure that each cell or module's voltage, current, and temperature does not exceed specific limits when charging or discharging a battery. These limits are known as SOA limits, and BMS ensures that residual energy in a battery is optimally utilised. BMS also protects batteries from deep discharge and over-voltage to prevent dangerous thermal runaway conditions and damage to the battery pack.

Li-ion batteries have different states of charging based upon their voltage, and Constant-current constant-voltage (CCCV) charging is a popular method accomplished by BMS. This efficient and safe charging method limits the charging current to a safe level and prevents overcharging. As shown in figure 1, CCCV charging involves a constant current charging stage and a constant voltage charging stage. During the constant current stage, a constant current is applied to the battery, gradually increasing the battery voltage as it charges. Once the battery reaches a specific voltage, the charging switches to the constant voltage stage. The charging voltage is held constant, and the charging current gradually decreases until the battery is fully charged.

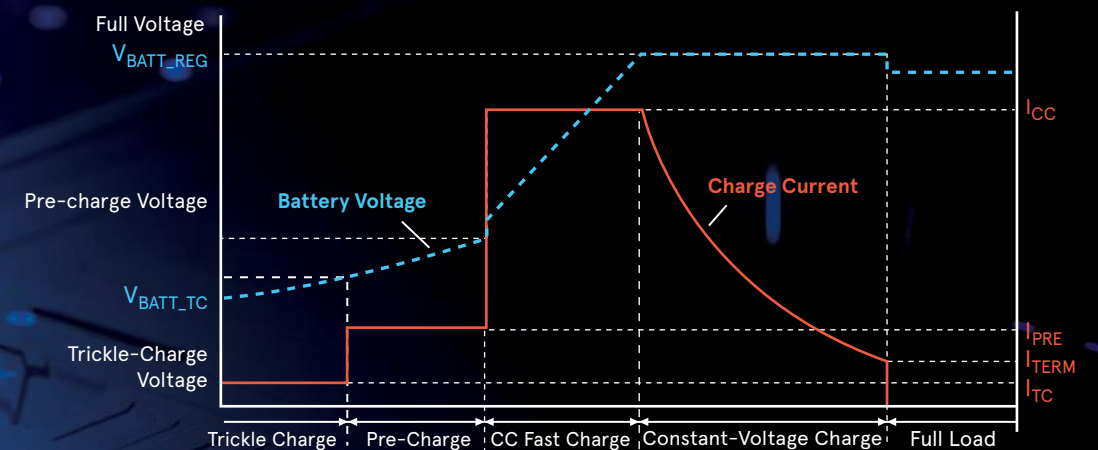
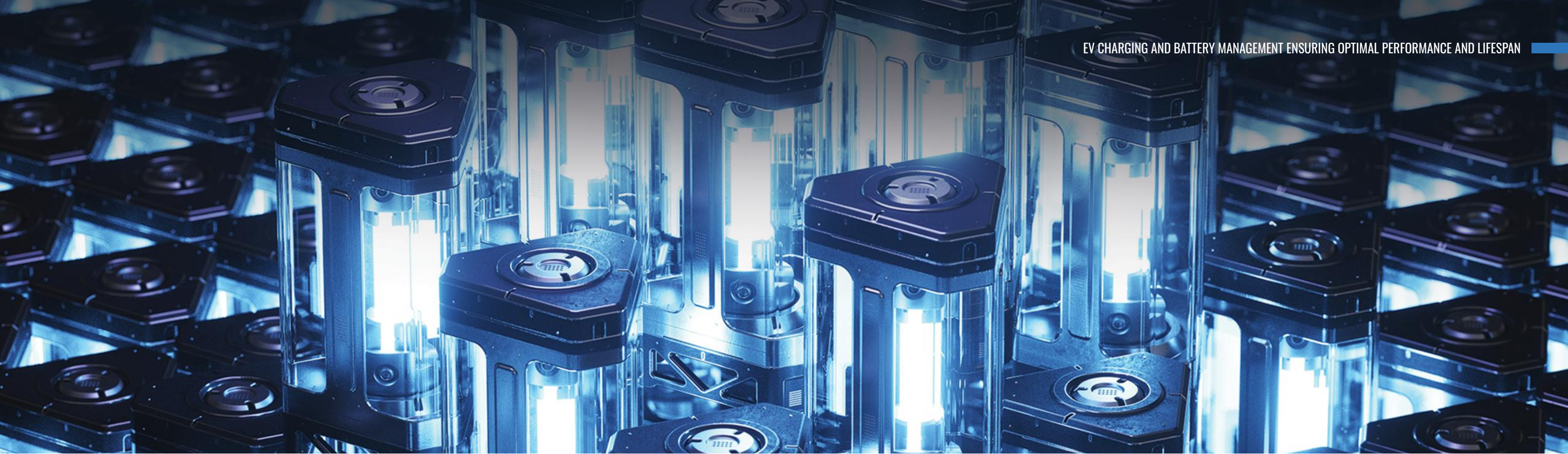

Figure 1: Constant-current constant-voltage battery charging scheme



FUNCTIONAL BLOCK DIAGRAM OF BMS

Figure 2 illustrates the BMS block diagram, which shows how the different components of the system work together to enhance the battery pack's performance and safety. The BMS comprises a Microcontroller/Microprocessor that processes battery information and regulates the charging and discharging procedures. The system also includes sensors and communication interfaces that gather and transmit data to other devices or systems.

The Cell Monitoring Units measure individual battery cells' voltage, current, and temperature and send this information to the BMS controller for processing. The controller then uses this data to manage the charging and discharging of the battery pack. It can also provide safety features like overcharge protection, over-discharge protection, and short circuit protection to prevent damage to the device or battery. Furthermore, the communication interface permits the BMS to exchange data with other systems or devices, such as the vehicle's main controller or a remote monitoring system.

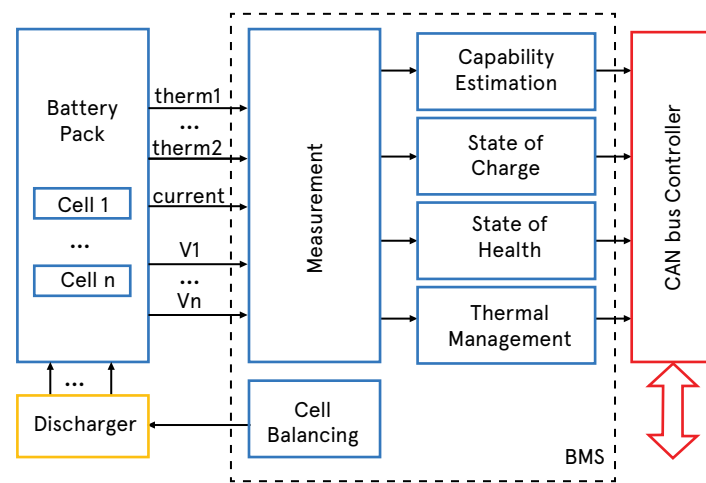

Figure 2: Functional block diagram of BMS

PRIMARY FUNCTION OF EV-BMS

A BMS for an Electric Vehicle battery manages and controls the battery's charging and discharging, monitors its state of charge and health, and ensures safe operation. The BMS's safety features are critical for EV safety, preventing dangerous situations. The BMS monitors the battery pack constantly, taking action to prevent damage or danger, making EVs safe and reliable transportation.

The BMS has several safety features:

- Cell balancing: The BMS ensures that each cell in the battery is charged and discharged equally, to prevent overcharging or undercharging of any cell, which could lead to thermal runaway or fire. This helps to maintain the overall health and longevity of the battery.
- State of Charge (SOC) estimation: The BMS constantly monitors the SOC of the battery, which is the amount of energy stored in the battery at any given time. This information is used to provide accurate range estimates to the driver and to prevent over-discharging of the battery.
- Thermal management: The BMS monitors the temperature of the battery and manages the cooling and heating systems to ensure that the battery is operating within safe temperature limits.

- Safety monitoring: The BMS continuously monitors the battery for any faults or malfunctions, and can take action to prevent damage to the battery or to the vehicle. If a fault is detected, the BMS can shut down the battery pack to prevent further damage or danger.
- Overvoltage and undervoltage protection: The BMS constantly monitors the voltage of each cell in the battery pack. If any cell voltage exceeds safe limits, the BMS will take action to prevent overcharging, which could lead to thermal runaway or fire. Similarly, if any cell voltage drops below safe limits, the BMS will take action to prevent over-discharging, which could lead to reduced battery life or damage.
- Overcurrent protection: The BMS monitors the current flowing in and out of the battery pack. If the current exceeds safe limits, the BMS will take action to prevent damage to the battery or to the vehicle.
- Thermal management: The BMS monitors the temperature of the battery pack and can activate cooling or heating systems to maintain safe temperatures. If the temperature exceeds safe limits, the BMS will take action to prevent damage to the battery or to the vehicle.
- Communication with the vehicle: The BMS communicates with other systems in the vehicle, such as the motor controller and the charging system, to ensure that they are operating safely and within their limits.

BATTERY MANAGEMENT AND EV CHARGING TYPES

Battery management systems come in different levels of complexity and can incorporate various technologies. The type of BMS used in an electric vehicle depends upon several factors, such as the battery pack's size, desired performance, safety levels, and budget for the system.

There are two types of EV charging: AC (alternating current) and DC (direct current) charging. With AC charging, the charging cable connects to an AC power source, such as a standard wall outlet or an AC charging station. The current flows through the cable and into the onboard charger, which converts it from AC to DC and sends it to the battery via the BMS.

The BMS manages and protects the battery during charging and discharging, ensuring it lasts as long as possible. Components that monitor the battery include devices that measure voltage and current, isolate signals, and ensure safety. With the prevalence of lithium-ion batteries in electric and hybrid electric vehicles, it's crucial to have a system that protects and monitors the battery.

OFF-BOARD AND ON-BOARD BMS

There are two types of BMS used for EV charging: An off-board and on-board. The main difference between an off-board BMS and an on-board BMS for an EV is the location of the BMS relative to the battery and the charging process. An off-board BMS is typically located in a charging station, separate from the vehicle, and manages the charging process of the battery whilst it is not connected to the vehicle. The BMS in an off-board charger may also be responsible for managing multiple charging stations and communicating with a central management system to optimise the charging process.

On the other hand, an on-board BMS is located within the EV and manages the charging process of the battery whilst it is connected to a charging station. The battery can be charged using a standard power outlet with the help of an onboard charger unit. To charge the battery packs, an on-board AC/DC converter module is used. This module converts the alternating current (AC) from an external power source, such as a charging station or wall outlet, into direct current (DC) that is used to charge the battery packs.

The cooperative operation of the BMS and the AC/DC converter module is crucial for the reliable and efficient charging of the battery packs in electric or hybrid electric vehicles. The BMS in an on-board charger may also be responsible for managing the battery's state of charge, optimising energy usage, and monitoring the battery's health and performance.



For the majority of users, a power supply of 120 VAC at 15 to 20 A is easily accessible and all onboard chargers should be capable of handling it. However, as charging time is a crucial factor for car drivers, some users can opt for 240 VAC which can provide faster charging times, but it will necessitate a more powerful power source.

Both off-board and on-board BMS have their advantages and disadvantages. Off-board BMS can be more cost-effective as they can manage multiple charging stations and don't require the complexity of on-board BMS. On the other hand, on-board BMS provides more control over the charging process and allows for more precise management of the battery's state of charge. Ultimately, the goal of both types of BMS is to ensure safe and efficient charging, extending the battery's life and improving overall performance.

CONCLUSION

Please visit our Technical Resources hub to explore the most recent trends, technologies, and design resources for Electric Vehicles (EVs).

[CLICK HERE](#)

onsemi

INTELLIGENT TECHNOLOGY BETTER FUTURE

LEARN MORE

LITTELFUSE SOLUTIONS FOR AC CHARGING STATION



1 POWER BOARD
Fuse, Circuit Breakers, MOV, AC Contactor, Residual Current Monitors

2 CHARGING GUN
Reed Sensor, Temperature Sensor, Snap Switch

3 CONTROL BOARD
Reed Relay, TVS Diode, Linear Optocoupler, Rotary Switch

4 AUXILIARY POWER SUPPLY
Fuse, PPTC, MOV, SIDACTor®, Schottky Diode



MOV: metal-oxide varistor
AC: alternate current
TVS: transient voltage suppression

PPTC: polymer positive temperature coefficient
SPD: surge protection device

BRING ON THE ELECTRIC REVOLUTION

EATON GREEN MOTION EV CHARGERS

EATON

VISIT EATON

ENABLE FAST, LOW-COST
AND SUSTAINABLE
CHARGING EVERYWHERE

The future of
transportation is electric.
How will you charge it?

Count on Eaton innovations to electrify your car, truck or fleet anywhere you need. Our charging solutions support flexible energy systems and intelligently integrate onsite energy resources – so you can optimize charging speed, sustainability and cost-effectiveness.

Scalable
Flexible solutions to
accelerate installations



Connected
Monitor and manage
energy usage



Smart
Digital technology enabling smart
energy decisions and control

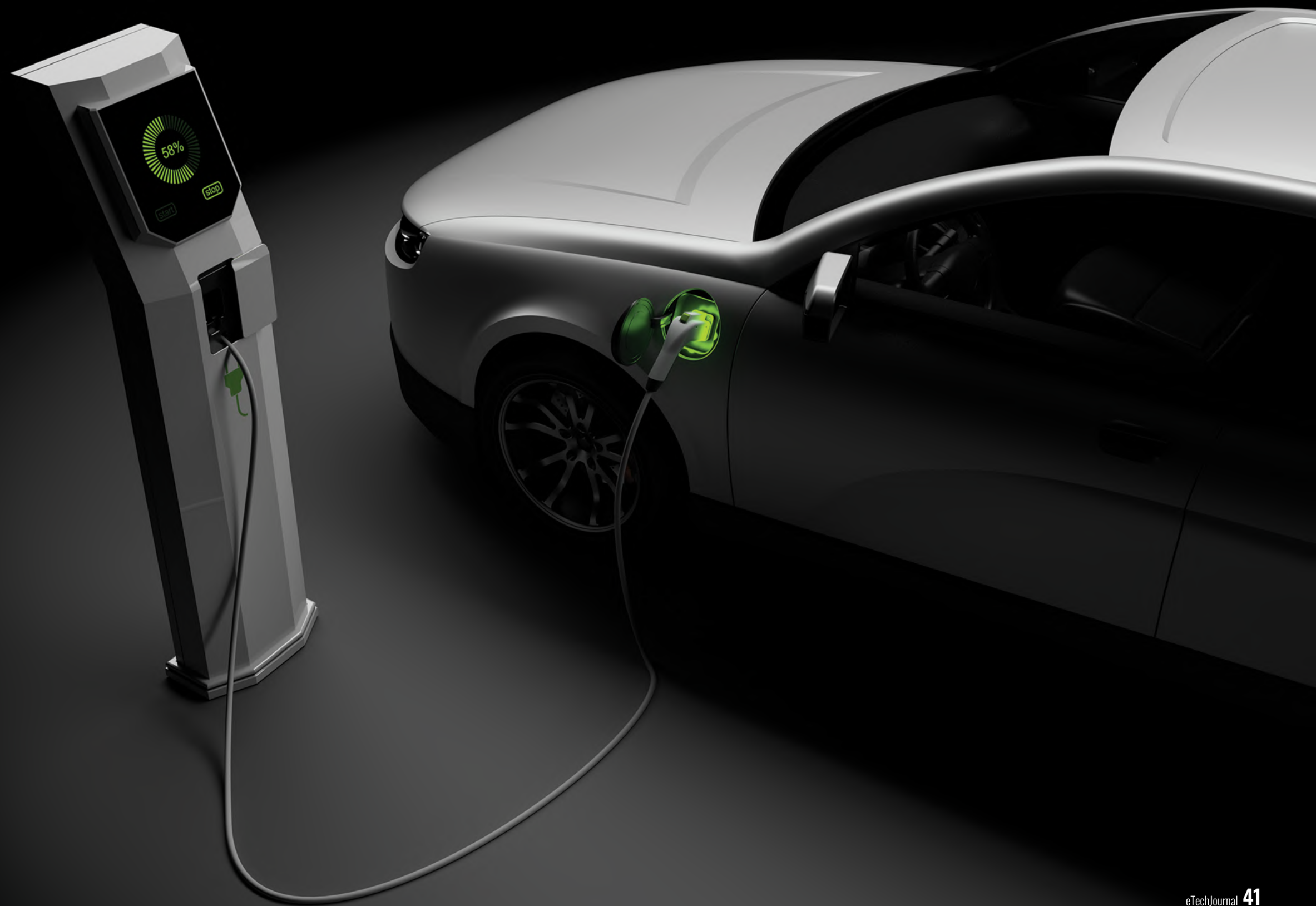

COMPARISON TABLE

	Green Motion EV Smart Breaker Chargers	Green Motion Building	Green Motion Building Pro	Green Motion Fleet	Green Motion Fleet Pro	Green Motion EV Charging Busway		
	Installs directly into Eaton loadcenters and panelboards ¹	Residential, EV wall charger	Multi-family and workplace charging solution	Commercial and destination charging solution for passenger vehicles	Commercial, high-power charging for fleet applications	Fleet and industrial charging solution for medium-duty trucks	Overhead EV charging for large fleet and industrial applications	
Product Specifications	Max power rating	32 A / 7.7 kW	32 A / 7.7 kW	40 A / 9.6 kW	48 A / 11.5 kW	80 A / 19.2 kW	80 A / 19.2 kW	
	Metering accuracy	± 0.2%	± 0.2%	± 1%	± 1%	± 1%	± 1%	
	Enclosure	2-pole circuit breaker	Plastic	Plastic	Plastic	Plastic	Metal	Metal
	Communication protocols	Wi-Fi	Wi-Fi	Wi-Fi, Ethernet, cellular	Wi-Fi, Ethernet, cellular	Wi-Fi, Ethernet, cellular	Wi-Fi, Ethernet, cellular	Wi-Fi, Ethernet, cellular
	Connector and cord	J1772 EV connector and 25-foot cord with patented LED design to indicate state	J1772 EV connector and 25-foot cord with patented LED design to indicate state	J1772 EV connector and 25-foot cord	J1772 EV connector and 25-foot cord	J1772 EV connector and 25-foot cord	J1772 EV connector and 25-foot cord	J1772 EV connector and 25-foot cord
	User interface	Status indicator	Status indicator	Display screen & status indicator	Touchscreen display & status indicator	Display screen & status indicator	Touchscreen display & status indicator	Status indicator
	Mounting options	Integrates directly into panel	Wall and pedestal options	Wall and pedestal options	Wall and pedestal options	Wall and pedestal options	Wall and pedestal options	Busway
	Access control ²	QR code	QR code	QR code & RFID	QR code & RFID	QR code & RFID	QR code & RFID	QR code
	Payment capabilities ²	QR code, mobile app	QR code, mobile app	QR code, RFID, mobile app	QR code, RFID, mobile app	QR code, RFID, mobile app	QR code, RFID, mobile app	QR code, mobile app
	Trade compliance	TAA	TAA	-	TAA	-	TAA	-
	CTEP compliant	-	-	Yes	- ³	Yes	- ³	-
	OCPD compliant (1.6J)	Yes	Yes	Yes	Yes	Yes	Yes	Yes
	Outdoor rating (NEMA3R)	-	Yes	Yes	Yes	Yes	Yes	-
	Energy Star certification	Yes	Yes	Yes	Yes	Yes	Yes	-
Target applications	Single family residential	Yes	Yes	-	-	-	-	
	Multi-family residential	Yes	Yes	Yes	Yes	-	-	
	Workplace and destination ⁴	-	-	Yes	Yes	Yes	Yes	
	Fleet depot	-	-	-	-	Yes	Yes	

¹ Install up to six EV smart breaker chargers² QR code, RFID card, and Mobile app provided by EV software provider³ CTEP compliance: Building Pro and Fleet Pro will have CTEP compliance post launch⁴ Destination charging includes retail parking lots, malls, sports arenas etc.

GREEN MOTION EV SMART BREAKER CHARGERS

CREATE NEW POSSIBILITIES WITH SMART CHARGING

Transportation is electrifying, but you don't need to pay a premium on your electric bill or change your driving habits. Intelligent, fast and cost-effective charging is here.

Enter Green Motion EV smart breaker chargers—delivering a fast AC charge, powered by smart breakers for residential, commercial and fleet applications. Eaton chargers create new possibilities through real-time energy insights and integration with onsite renewables and energy storage systems. Leverage our industry-first technology to advance smart, sustainable energy systems to power today and tomorrow

Features

- Fast AC Level 2 charging at 7.7 kW, 240 Vac
- Charges up to 6 electric vehicles (EV's) with Pow-R-Line 3X panelboard or up to 20 EVs with the Eaton integrated facility switchboard (IFS)
- Multiple installation options offer flexibility and efficiency
- Lower cost of maintenance as compared to traditional EV chargers
- Real-time and remote access allows you to optimize charging times and take part in smart grid programs
- Control the rate of charge to manage peak loads
- Gain real-time insights through revenue-grade metering accuracy
- Set charging times to reduce costs with the Green Motion EV Charger Manager app
- Open Charge Point Protocol (OCPP) 1.6J certification enables integration with your preferred charge management solution

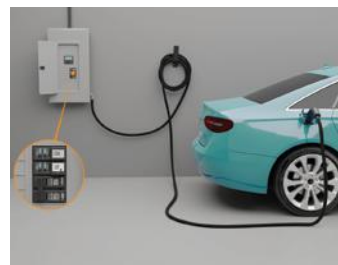

DIRECT CONNECT KIT

Is your power source near your charging site? Our Green Motion EV smart breaker chargers can install directly into Eaton BR loadcenters or Pow-R-Line 3X panelboards.

The direct connect kit includes:

- 7.7 kW EV smart breaker charger
- J1772 EV connector and 25-foot cord
- Cord management bracket

SPECIFICATIONS

GMEV32BAB-DC

- EV direct connect kit 32 A, BAB bolt-on 2P 40 A

GMEV32BR-DC

- EV direct connect kit 32 A, BR plug-on 2P 40 A

DIRECT CONNECT + JUNCTION BOX KIT

Will your EV be parked more than 25-feet away from the loadcenter or panelboard? If so, you'll need the direct connect + junction box kit (junction box can be up to 150 feet away from the loadcenter or panelboard).

The direct connect + junction box kit includes:

- 7.7 kW EV smart breaker charger
- J1772 EV connector and 25-foot cord
- Junction box
- Cord management bracket

SPECIFICATIONS

GMEV32BAB-JB

- EV junction box kit 32 A, BAB bolt-on 2P 40 A

GMEV32BR-JB

- EV junction box kit 32 A, BR plug-on 2P 40 A

EV LOADCENTER

When you need to charge up to five EVs, our Green Motion EV multi-charge system enables fast, convenient charging in a circuit breaker form factor that installs directly into the BR loadcenter.

AS-SHOWN SOLUTION

4x GMEV32BR-JB

- 7.7 kW EV smart breaker charger
- J1772 EV connector and 25-foot cord
- Junction box
- Cord management bracket

1x BRP40B200R

- BR PON loadcenter, 200 A, main breaker, 40 space, N3R

EV PANELBOARD AND SWITCHBOARD

How will you support EV charging for multiple charge points? Whether you're enabling charging for a multi-family dwelling, commercial application, educational campus or a parking garage, Eaton provides the EV panel you need to address your charging application and all the necessary power distribution equipment to support it. Rated for both indoor and outdoor applications, the Eaton Pow-R-Line 3X panelboard supports up to six EV chargers and the IFS supports up to 20 EV chargers

Features

- Fast AC Level 2 charging at 7.7 kW, 240 Vac
- Highly scalable solution: adding new EV chargers is as easy as adding a new circuit breaker
- Restricted access to the EV panel protects against vandalism
- Remotely monitor EV chargers, manage access to users and control the rate of charge (load management) to make sure total service capacity is never breached
- OCPP 1.6J certification enables integration with your preferred charge management solution

EV WALL CHARGER, HARDWIRED

The EV wall charger installs in both indoor and outdoor settings.

This kit includes:

- 7.7 kW EV smart breaker charger
- J1772 EV connector and 25-foot cord
- Built-in cord management

SPECIFICATIONS

GMEV32BR-WC

- EV wall charger (hardwired) 32 A, BR 2P 40 A

EV WALL CHARGER WITH PLUG

Simple installation in both indoor and outdoor settings with 240 V receptacle.

This kit includes:

- 7.7 kW EV smart breaker charger
- J1772 EV connector and 25-foot cord
- Built-in cord management

SPECIFICATIONS

GMEV32BR-WCPL

- EV wall charger plug-in (plugs into a 240 V receptacle, not included) 32 A, BR 2P 40 A

GREEN MOTION EV SMART BREAKER CHARGERS

ACCESSORIES

Get what you need to customize and optimize your Green Motion EV charger installation:

SPECIFICATIONS



EVCC-LED
Replacement J1772 EV connector and 25-foot cord and cord management bracket



EVCC-LED-JB
Replacement J1772 EV connector and 25-foot cord, cord management bracket and junction box



BABEVEM2040 (BAB bolt-on 2P 40 A)
BREVEM2040 (BR plug-on 2P 40 A)
Replacement EV smart breaker charger



GMEV32HSTR-BKR
Premium cord holster for all applications



EATON'S MOBILE APPLICATION

Eaton's Green Motion EV Charger Manager app will help you track energy usage from anywhere, manage chargers and save on energy costs by taking advantage of off-peak charging rates. Download the app on iOS and Google Play stores to receive notifications on charging status, power outages, ground fault conditions and more.



GREEN MOTION BUILDING

FAST AC CHARGING FOR PASSENGER VEHICLES



GREEN MOTION BUILDING PRO

FAST AC CHARGING FOR PASSENGER VEHICLES AND COMMERCIAL VEHICLES



GREEN MOTION FLEET

ENSURE TIMELY DELIVERY



GREEN MOTION FLEET PRO

HIGH-POWER FLEET DEPOT AND INDUSTRIAL CHARGING

Most charging will take place where people park their cars – at school, work, shopping and in nearly every commercial setting, that's where Eaton Green Motion Building comes in.

Features

- AC Level 2 charging at 9.6 kW, 240 Vac
- Dynamic load management with ability to throttle charging rate, minimizing or avoiding infrastructure upgrades
- Gain real-time insights through energy metering and Wi-Fi, Ethernet and cellular
- OCPP 1.6J certification enables integration with your preferred charge management solution
- Secure access for authorized users through QR codes and RFID
- Support an easy and intuitive charging experience with a 4.3" LCD display
- Outdoor-rated enclosure with flexible installations including wall mount, single- or dual-pedestal mount

SPECIFICATIONS

GMEV40CME1B-WC

- 9.6 kW AC Level 2 wall charger
- J1172 EV connector and 25-foot cord
- Premium cord holster
- Mounting option: wall or pedestal
- Connectivity: Wi-Fi, Ethernet

GMEV40CMC1B-WC

- 9.6 kW AC Level 2 wall charger
- J1172 EV connector and 25-foot cord
- Premium cord holster
- Mounting option: wall or pedestal
- Connectivity: Wi-Fi, Ethernet

Smart, fast charging for vehicles in commercial and destination locations.

Features

- AC Level 2 charging at 11.5 kW, 240 Vac with adjustable output between 32 A, 40 A and 48 A based on infrastructure capacity
- Dynamic load management with ability to throttle charging rate, minimizing or avoiding infrastructure upgrades
- Gain real-time insights through energy metering and Wi-Fi, Ethernet and cellular
- OCPP 1.6J certification enables integration with your preferred charge management solution
- Secure access for authorized users through QR codes and RFID
- Support an easy and intuitive charging experience with a 5" LCD touchscreen display
- Outdoor-rated enclosure with flexible installations including wall mount, single- or dual-pedestal mount

SPECIFICATIONS

GMEV40CME1B-WC

- 11.5 kW AC Level 2 wall charger
- J1772 EV connector and 25-foot cord
- Premium cord holster
- Mounting option: wall or pedestal
- Connectivity: Wi-Fi, Ethernet

GMEV48CMC1-WC

- 11.5 kW AC Level 2 wall charger
- J1772 EV connector and 25-foot cord
- Premium cord holster
- Mounting option: wall or pedestal
- Connectivity: Wi-Fi, Ethernet, cellular

Energize your fleet to hit the road—quickly, cost-effectively and sustainably. With Eaton Green Motion Fleet chargers, you can enable efficient deployment and charging of last mile delivery vehicles, light and medium-duty trucks and school buses.

Features

- AC Level 2 charging at 19.2 kW, 240 Vac
- Dynamic load management with ability to throttle charging rate, minimizing or avoiding infrastructure upgrades
- Gain real-time insights through energy metering and Wi-Fi, Ethernet and cellular
- OCPP 1.6J certification enables integration with your preferred charge management solution
- Secure access for authorized users through QR codes and RFID
- Support an easy and intuitive charging experience with a 4.3" LCD display
- Outdoor-rated enclosure with flexible installations including wall mount, single- or dual-pedestal mount

SPECIFICATIONS

GMEV80CME1-WC

- 19.2 kW AC Level 2 wall charger
- J1772 EV connector and 25-foot cord
- Premium cord holster
- Mounting option: wall or pedestal
- Connectivity: Wi-Fi, Ethernet

GMEV80CMC1-WC

- 19.2 kW AC Level 2 wall charger
- J1772 EV connector and 25-foot cord
- Premium cord holster
- Mounting option: wall or pedestal
- Connectivity: Wi-Fi, Ethernet, cellular

Enable cost-effective deployment and operation of EV charging infrastructure to charge last mile delivery vehicles, light/medium-duty trucks and school buses. The robust metal enclosure is designed for maximum durability in industrial settings.

Features

- AC Level 2 charging at 19.2 kW, 240 Vac
- Dynamic load management with ability to throttle charging rate, minimizing or avoiding infrastructure upgrades
- Gain real-time insights through energy metering and Wi-Fi, Ethernet and cellular
- OCPP 1.6J certification enables integration with your preferred charge management solution
- Secure access for authorized users through RFID cards
- Support an easy and intuitive charging experience with a 5" LCD touchscreen display
- Outdoor-rated enclosure with flexible installations including wall mount, single- or dual-pedestal mount

SPECIFICATIONS

GMEV80CME1-WC

- 19.2 kW AC Level 2 wall charger
- J1772 EV connector and 25-foot cord
- Premium cord holster
- Mounting option: wall or pedestal
- Connectivity: Wi-Fi, Ethernet

GMEV80CMC1-WC

- 19.2 kW AC Level 2 wall charger
- J1772 EV connector and 25-foot cord
- Premium cord holster
- Mounting option: wall or pedestal
- Connectivity: Wi-Fi, Ethernet, cellular



UNIVERSAL SINGLE AND DUAL PEDESTALS

GET THE OPTION
YOU NEED



GREEN MOTION EV CHARGING BUSWAY

Features

- Powder-coated stainless steel for durability, heavy-duty, 14 gauge
- NEMA 3R rated
- For use with GMEV32BR-WC, GMEV40CME1B-WC, GMEV40CMC1B-WC, GMEV48CME1-WC, GMEV48CMC1-WC, GMEV80CME1B-WC, GMEV80CMC1B-WC, GMEV80CME1-WC, GMEV80CMC1-WC (charging stations sold separately)

SPECIFICATIONS

EV single port pedestal: (1) GMEV-PED

- Requires (1) charging station sold separately

EV dual port pedestal: (1) GMEV-DPED

- Requires (2) charging station(s) sold separately

This fast and flexible charging solution is designed for last mile delivery, fleet and industrial applications. EV charging busway provides overhead chargers with cable management, supporting passenger vehicles and medium-duty trucks. The busway-based technology enables scalable, flexible charging with easy installation, service and the ability to quickly add more chargers or reconfigure chargers as your EV needs evolve.

Features

- 19.2 kW at 240 Vac (80 A) with integrated 100A circuit breaker
- Overhead charging solution that avoids conduits and trenching

- Prevent disruption to existing parking and conveyor structures, reduce obstacles on the ground level.
- Dynamic load management with ability to throttle charging rate, minimizing or avoiding infrastructure upgrades
- OCPP 1.6J certification enables integration with your preferred charge management solution
- Ethernet and cellular connectivity
- ENERGY STAR® certification means our chargers help you save energy
- SAE J1772 EV connector and 25-foot cord



CONCLUSION

Learn more about
Eaton Green Motion
EV chargers,

[CLICK HERE](#)

TECHNICAL RESOURCES CENTRE

Learn innovations,
Stay informed,
Be inspired

A comprehensive selection of products framed into design situations, latest news and trends, design tools and resources to enable you to move from block diagram concept to solution for your vertical segment applications.

LEARN MORE



Explore our expanding library of:



Whitepapers



Articles



How To's



Webinars



Podcast